



Purpose: VFD-F software version upgrade

Explanation:

Software version : 0.75KW~ 90KW (1HP~125HP): V1.202 → V1.302
110KW~220KW (150HP~300HP): V3.10 → V1.302

| No. | Type | Old version | New version | The CPU starts the serial number |
|-----|-------------|-------------|-------------|----------------------------------|
| 1 | VFD450F43A | 1.202 | 1.302 | 6W0510001-29 |
| 2 | VFD370F43A | 1.202 | 1.302 | 6W0510001-6 |
| 3 | VFD750F43A | 1.202 | 1.302 | 6W0510001-23 |
| 4 | VFD550F43A | 1.202 | 1.302 | 6W0510003-4 |
| 5 | VFD022F43A | 1.202 | 1.302 | 6W0520001-13 |
| 6 | VFD1320F43A | 3.10 | 1.302 | 6W0530001-4 |
| 7 | VFD2200F43A | 3.10 | 1.302 | 6W0530001 |
| 8 | VFD1600F43A | 3.10 | 1.302 | 6W0530001-2 |
| 9 | VFD037F43A | 1.202 | 1.302 | 6W0530030-71 |
| 10 | VFD1100F43C | 3.10 | 1.302 | 6W1020002 |
| 11 | VFD015F43A | 1.202 | 1.302 | 6W1030001-15 |
| 12 | VFD075F43B | 1.202 | 1.302 | 6W1050018-302 |
| 13 | VFD015F23A | 1.202 | 1.302 | 6W1090001 |
| 14 | VFD007F43A | 1.202 | 1.302 | 6W1120001 |

Content:

1. New function
2. Function change
3. Function correction

New Function

1. Add new parameter Pr00-15: Stall torque output(N.M.)

00-15 Stall torque output(N.M.)

This parameter shows stall torque output in Newton metre

2. Add new parameter Pr02-06: Line Start Lockout function selection

| 02-06 | Line Start Lockout | | Factory Setting | 01 |
|-------|--------------------|----|---|----|
| | Setting Range | 00 | Enabled | |
| | | 01 | Disabled | |
| | | 02 | If the command to run still remains after resetting, the inverter will continue to run. | |

Pr02-06=2 :

This determines the following matter. The VFD (Variable-Frequency Drive) detects an error message and eliminates the error. If the command terminal remains running in the external function terminals, you can simply press the RESET button to make the VFD running again.

3. Add new parameter Pr02-07: ACI (4~20mA) Loss of ACI Signal function selection

| 02-07 | ACI (4~20mA) Loss of ACI Signal | | Factory Setting | 01 |
|-------|-----------------------------------|----|--|----|
| | Setting Range | 00 | Decelerate to zero Hz | |
| | | 01 | Show E.F. | |
| | | 02 | Continue operation by following the last frequency command | |
| | | 03 | Use loss of ACI Signal Frequency of Pr02-16 | |

4. Add new parameter Pr02-09: Special Display function selection

| 02-09 | Special Display | | ⚡ | Factory Setting | 00 |
|-------|-----------------|----|---|-----------------|----|
| | Setting Range | 00 | A displays outputs current of AC drive | | |
| | | 01 | U displays DC-Bus voltage of AC drive | | |
| | | 02 | E displays RMS of output voltage | | |
| | | 03 | P displays feedback signal | | |
| | | 04 | PLC displays auto procedure state | | |
| | | 05 | T displays heat sink's temperature | | |
| | | 06 | The keypad's screen displays both target value and feedback value controlled by PID (proportional–integral–derivative controller (PID controller)). | | |

📖 When Pr02-09 is set to be 6, the keypad's screen displays both target value and feedback value controlled by PID as shown below.

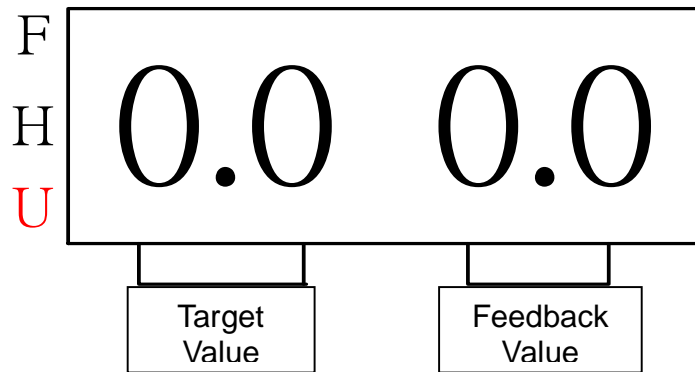

5. Add new parameter Pr02-14: Source of Second Frequency Command

| 02-14 Source of Second Frequency Command | | ↗ | Factory Setting | 00 |
|---|----|---|-----------------|----|
| Setting Range | 00 | Master Frequency Setting is controlled by PID controller. | | |
| | 01 | Master frequency is controlled by an external terminal via analog input AVI: DC 0~+10V. | | |
| | 02 | Master frequency is controlled by an external terminal via analog input ACI1: DC 4~ 20mA. | | |
| | 03 | Master frequency is controlled by an external terminal via analog input ACI2: DC 4~ 20mA | | |
| | 04 | Master frequency is handled via RS485 serial communication (RJ-11). | | |
| | 05 | External Reference Master frequency via External Reference. | | |

📖 This parameter sets the source of inverter's second frequency.

6. Add new parameter Pr02-15: Source of Second Operation Command

| 02-15 Source of Second Operation Command | | ↗ | Factory Setting | 00 |
|---|----|--|-----------------|----|
| Setting Range | 00 | Controlled by the digital keypad | | |
| | 01 | Controlled by the external terminals, keypad STOP enabled. | | |
| | 02 | Controlled by the external terminals, keypad STOP disabled | | |
| | 03 | Controlled by the RS-485 communication interface keypad STOP enabled. | | |
| | 04 | Controlled by the RS-485 communication interface keypad STOP disabled. | | |

📖 This parameter sets the source of inverter's second operation command.

7. Add new parameter Pr02-16: Loss of ACI Signal

| | | | | |
|--------------|---------------------------|------------------------------------|-----------------|------|
| 02-16 | Loss of ACI Signal | ↗ | Factory Setting | 0.00 |
| | Setting Range | 0.00-Highest operational frequency | | |

 This parameter sets the loss of ACI signal

8. Add new parameter Pr03-00~Pr03-07: Multi-function Output Terminal function selection

| | | | | |
|--------------|------------------------------|-------------------------------|-----------------|----|
| 03-00 | Multi-function Output | Terminal 1 (Relay 1) | | |
| 03-01 | Multi-function Output | Terminal 2 (Relay 2) | | |
| 03-02 | Multi-function Output | Terminal 3 (Relay 3) | | |
| 03-03 | Multi-function Output | Terminal 4 Relay 4) | | |
| 03-04 | Multi-function Output | Terminal 5 (Relay 5) | | |
| 03-05 | Multi-function Output | Terminal 6 (Relay 6) | | |
| 03-06 | Multi-function Output | Terminal 7 (Relay 7) | | |
| 03-07 | Multi-function Output | Terminal 8 (Relay 8) | | |
| | Setting Range | 00-43 | Factory Setting | 00 |

Functions Table

| Settings | Functions | Descriptions |
|----------|----------------------------------|--|
| 38 | Loss of an ACI signal Indication | When there is a loss of an ACI signal indication, the corresponding relay output will be closed. |
| 39 | HOA-Hand mode indication | Under the Hand mode indication of HOA mode, the corresponding relay output will be closed. |
| 40 | HOA-Off mode indication | Under the Off mode indication of HOA mode, the corresponding relay output will be closed. |
| 41 | HOA-Auto mode indication | Under the Automatic mode indication of HOA mode, the corresponding relay output will be closed. |
| 42 | Fire mode indication | When Fire mode indication is activated, the corresponding relay output will be closed. |
| 43 | Bypass fire mode indication | Under the Bypass fire mode indication, the corresponding relay output will be closed. |

9. Add new parameter Pr03-15: DC Fan Control function selection

| | | | | |
|--------------|-----------------------|----|--|----|
| 03-15 | DC Fan Control | | Factory Setting | 00 |
| | Setting Range | 00 | Fan runs on power up. | |
| | | 01 | Fan begins upon a RUN command. Fan stops 1 minute after a STOP command. | |
| | | 02 | Fan begins upon a RUN command. Fan stops 1 minute after a STOP command. | |
| | | 03 | Fan is controlled by temperature. Approximately a 60°C temperature will start the fan. | |
| | | 04 | Unusual Fan status warning, inverter runs continuously at more than 150hp. | |

10. Add new parameter Pr04-00~04-07: Multi-function Input Terminal function selection

| | | | | |
|--------------|--|-------|-----------------|----|
| 04-00 | Multi-function Input Terminal 1 | | Factory Setting | 01 |
| 04-01 | Multi-function Input Terminal 2 | | Factory Setting | 02 |
| 04-02 | Multi-function Input Terminal 3 | | Factory Setting | 03 |
| 04-03 | Multi-function Input Terminal 4 | | Factory Setting | 04 |
| 04-04 | Multi-function Input Terminal 5 | | Factory Setting | 05 |
| 04-05 | Multi-function Input Terminal 6 | | Factory Setting | 07 |
| 04-06 | Multi-function Input Terminal 7 | | Factory Setting | 08 |
| 04-07 | Multi-function Input Terminal 8 | | Factory Setting | 09 |
| | Setting Range | 00~43 | | |

| Setting | Functions | Description | | | | | | | | | |
|----------|---|---|--|---------|----------|---------|----------|-----------|----------|-----------|----------|
| 34 | Enable source of the second frequency | ● This terminal allows you to choose the master frequency or the second one. | | | | | | | | | |
| 35 | Enable source of the second operation command | ● This terminal allows you to choose the master operation command or the second one. | | | | | | | | | |
| 36 | Motor No.5 output disabled | <ul style="list-style-type: none"> When multiple motors are controlled by an AC drive, these settings will allow the corresponding motor to disable and ignore this motor. AC drive will not accept the "Motor Output Disabled signal" when it is running. | | | | | | | | | |
| 37 | Motor No.6 output disabled | | | | | | | | | | |
| 38 | Motor No.7 output disabled | | | | | | | | | | |
| 39 | Motor No.8 output disabled | | | | | | | | | | |
| 40 | HOA-Hand mode indication | <ul style="list-style-type: none"> This terminal enables HOA function. <table border="1" style="margin-left: 40px;"> <tr> <td></td> <td>MI40 ON</td> <td>MI40 OFF</td> </tr> <tr> <td>MI41 ON</td> <td>Off mode</td> <td>Auto mode</td> </tr> <tr> <td>MI41 OFF</td> <td>Hand mode</td> <td>Off mode</td> </tr> </table> | | MI40 ON | MI40 OFF | MI41 ON | Off mode | Auto mode | MI41 OFF | Hand mode | Off mode |
| | MI40 ON | MI40 OFF | | | | | | | | | |
| MI41 ON | Off mode | Auto mode | | | | | | | | | |
| MI41 OFF | Hand mode | Off mode | | | | | | | | | |
| 41 | HOA-Auto mode indication | <p>Pr02-00 Refer to Pr02-00 for the source of frequency</p> <p>Auto mode : Pr02-14 Refer to Pr02-14 for the source of frequency. Pr02-15 Refer to Pr02-15 for source of operation command</p> <p>Off mode: AC Drive is permanently off.</p> | | | | | | | | | |
| 42 | (NO) Fire mode (NO) | In accordance with Pr11-15[Fire Mode], this terminal can start the Fire Mode | | | | | | | | | |
| 43 | Fire mode (NC) | | | | | | | | | | |

11. Add new parameter Pr04-24: Summation of External Frequency Sources function selection

| 04-24 | Summation of External Frequency Sources | | Factory setting | 00 |
|-------|---|----|--------------------------------------|----|
| | Setting Range | 00 | No function | |
| | | 01 | AVI+ACI1 | |
| | | 02 | ACI1+ACI2 | |
| | | 03 | ACI2+AVI | |
| | | 04 | Communication master frequency +AVI | |
| | | 05 | Communication master frequency +ACI1 | |
| | | 06 | Communication master frequency+ACI2 | |
| | | 07 | First frequency + Second Frequency | |
| | | 08 | First frequency + Second Frequency | |

12. Add new parameter Pr04-25: Summation of First External Frequency Source

| | | | |
|--------------|---|-----------------|--------------------------------|
| 04-25 | Summation of First External Frequency Source ⚡ | Factory Setting | 00 |
| | Setting Range | 00 | Digital Keypad |
| | | 01 | AVI External Terminal AVI |
| | | 02 | External Terminal ACI1 |
| | | 03 | External Terminal ACI2 |
| | | 04 | RS-485 communication interface |

13. Add new parameter Pr04-26: Summation of Second External Frequency Source

| | | | |
|--------------|--|-----------------|--------------------------------|
| 04-26 | Summation of Second External Frequency Source ⚡ | Factory Setting | 00 |
| | Setting Range | 00 | Digital Keypad |
| | | 01 | External Terminal AVI |
| | | 02 | External Terminal ACI1 |
| | | 03 | External Terminal ACI2 |
| | | 04 | RS-485 Communication Interface |

14. Add new parameter Pr06-18: Recording Mid/Low Voltage while running the AC Drive

| | | | |
|--------------|---|-----------------|--|
| 06-18 | Recording Mid/Low Voltage while running the AC Drive | Factory Setting | 00 |
| | Setting Range | 00 | None Recorded Low Voltage, Parameter Reset Automatically |
| | | 01 | None Recorded Low Voltage, Parameter Reset Manually |
| | | 02 | Recorded Low Voltage, Parameter Reset Manually |

15. Add new parameter Pr07-10: Poles of Motor

| | | | |
|--------------|-------------------------|-----------------|---|
| 07-10 | Poles of Motor ⚡ | Factory setting | 4 |
| | Setting Range | 2~10 | |

16. Add new parameter Pr07-11: Reserved

| | | | |
|--------------|-------------------|-----------------|--|
| 07-11 | Reserved ⚡ | Factory setting | |
| | Setting Range | | |

17. Add new parameter Pr09-00: Communication Address

| | | | | |
|--------------|------------------------------|---|-----------------|----|
| 09-00 | Communication Address | ⚡ | Factory Setting | 01 |
| | Setting Range | | | |
| | | When Pr09-09=0, Setting range is 01~254 | | |
| | | When Pr09-09=1, Setting range is 01~127 | | |
| | | When Pr09-09=2, Setting Range is 01~254 | | |

18. Add new parameter Pr09-09: Switching between Modbus & BACnet

| | | | | |
|--------------|--|----|--------------------|----|
| 09-09 | Switching between Modbus & BACnet | ⚡ | Factory Setting | 00 |
| | Setting Range | 00 | Modbus Mode | |
| | | 01 | BACnet Master Mode | |
| | | 02 | BACnet Slaver Mode | |

 This parameter determines the switch between Modbus and BACnet.

19. Add new parameter Pr09-10: BACnet DNET

| | | | | |
|--------------|--------------------|----------|-----------------|----|
| 09-10 | BACnet DNET | ⚡ | Factory Setting | 01 |
| | Setting Range | 01~65535 | | |

 This parameter determines the final IP address of the BACnet.

20. Add new parameter Pr09-11: BACnet Device Instance

| | | | | |
|--------------|-------------------------------|----------|-----------------|----|
| 09-11 | BACnet Device Instance | ⚡ | Factory Setting | 00 |
| | Setting Range | 00~65535 | | |

 This parameter determines the serial number of the BACnet.

21. Add new parameter Pr09-12: DCC password

| | | | | |
|--------------|---------------------|---------|-----------------|---|
| 09-12 | DCC password | ⚡ | Factory Setting | 0 |
| | Setting Range | 0~65535 | | |

 This parameter determines the DCC password of the BACnet.

The proprietary objects, properties and data type supported by the BACnet.

| Property Type | Object Type supported | | |
|------------------------|-----------------------|------------------------|------------------------|
| | Device supported | Analog Value supported | Binary Value supported |
| Object Identifier | X | X | X |
| Object Name | X | X | X |
| Object Type | X | X | X |
| System Status | X | | |
| Vendor Name | X | | |
| Vendor Identifier | X | | |
| Model Name | X | | |
| Firmware Revision | X | | |
| Appl Software revision | X | | |
| Protocol Version | X | | |
| Protocol Revision | X | | |
| Services Supported | X | | |
| Object Types supported | X | | |
| Object List | X | | |
| Max APDU Length | X | | |
| Segmentation Support | X | | |
| APDU Timeout | X | | |
| Number ADPU Retires | X | | |
| Max_Master | X | | |
| Max_Info_Frames | X | | |
| Device Address Binding | X | | |
| Database Revision | X | | |
| Present Value | | X | X |
| Status Flag | | X | X |
| Event State | | X | X |
| Out-of-Service | | X | X |
| Units | | X | |
| Priority Array | | X* | X* |
| Relinquish Default | | X* | X* |
| Active Text | | | X |
| Inactive Text | | | X |

* Only with commandable values

VFDF-Analog Values Description :

| ID | Object Name | Description | Unit | |
|----|---------------|--------------------------|----------------|---|
| 0 | AV00:RESERVED | software version(.xx) | NO_UNITS | R |
| 1 | AV01:ERROP | Error Code(xx.) | NO_UNITS | R |
| 2 | AV02:LEDOP | VFDF status(xx.) | NO_UNITS | R |
| 3 | AV03:FSET | Frequency Command(xx.xx) | HERZ | R |
| 4 | AV04:FOUT | Output Frequency(xx.xx) | HERZ | R |
| 5 | AV05:OUTAMP | Output Current(xx.x) | AMPERES | R |
| 6 | AV06:DCBUS | DC Bus Voltage(xxx.x) | VOLTS | R |
| 7 | AV07:OUTACV | Output Voltage(xxx.x) | VOLTS | R |
| 8 | AV08:PFANGLE | PF angle(xx.xx) | DEGREE_ANGULAR | R |
| 9 | AV09:POUT | Output Power(xx.xx) | KILPWATTS | R |

| | | | | |
|----|---------------------|------------------------------------|------------------------------|-----|
| 10 | AV10:PVFB | PID feedback physical signal (x.x) | NO_UNITS | R |
| 11 | AV11:SENSOR | PID feedback (xx.xx) | PERCENT | R |
| 12 | AV12:USERDL | Low part of user define (xx.xx) | NO_UNITS | R |
| 13 | AV13:USERDH | High part of user define(xxxx) | NO_UNITS | R |
| 14 | AV14:PLC_TIME | PLC time (xxxx) | UNIT_SECOND | R |
| 15 | AV15:TQ_RATIO | Torque(xx.x) | UNIT_NEWTON_METER | R |
| 16 | AV16:CMD_REM | (RUN/STOP/JOG/FWD/REV) | NO_UNITS(resolution 1.0) | C |
| 17 | AV17:FCMAIN | Frequency command | HERTZ | C |
| 18 | AV18:SCMD_REM | (EF/Reset/BB) | NO_UNITS(resolution 1.0) | C |
| 19 | AV19:PARAMETERID | Parameter ID set | 0.0~65535.0 (resolution 1.0) | R/W |
| 20 | AV20:PARAMETERVALUE | Parameter value set | 0.0~65535.0 | R/W |

- 📖 To set up object AV16 from the BACnet Communication Protocol, Pr02-01 has to be set as 3 or 4.
- 📖 To set up object AV17 from the BACnet Communication Protocol, Pr02-00 has to be set as 4.
- 📖 To set up communication parameter from BACnet, please set up the object AV19 then set up object AV20.
- 📖 Please refer to the description of Group 00 to set up objects AV00 to AV15.
- 📖 Please refer to Pr09-06 for the description of the object AV16.
- 📖 Please refer to Pr09-07 for the description of the object AV17.
- 📖 Please refer to Pr09-08 for the description of the object AV18.

VFDF-Binary Values:

| ID | Object Name | Description | Inactive/Active | |
|----|-------------------------|-------------|------------------|---|
| 0 | BV00:Ready or Not-Ready | Ready State | Not Ready/ Ready | R |

For current Value Access Types, R = Read-only, R/W = Writable, C = Commandable. Commandable values support priority arrays and relinquish defaults.

22. Add new parameter Pr10-12: PID Mode

| | | | | |
|--------------|-----------------|----|-----------------------|----|
| 10-12 | PID Mode | | Factory setting | 00 |
| | Setting Range | 00 | PID control by hand | |
| | | 01 | Automatic PID control | |

- 📖 This parameter allows you to choose PID control by hand or automatic PID control.
- 📖 When the set up is Automatic PID Control, you can adjust Kp from Pr10-03[Proportional Gain], adjust TI from Pr10-04[Integral Time] and adjust Td from Pr10-05[Differential Time].

23. Add new parameter Pr11-01: Circulative Control function selection

| | | | | |
|--------------|----------------------------|----|--|----|
| 11-01 | Circulative Control | | Factory Setting | 00 |
| | Setting Range | 00 | No function | |
| | | 01 | Fixed Time Circulation (by time) | |
| | | 02 | Fixed amount circulation (by PID) | |
| | | 03 | Fixed amount control (one AC drive runs with 8 motors) | |
| | | 04 | Fixed Time Switch + Fixed Amount Circulation | |
| | | 05 | Fixed Time Switch +Fixed Amount Control | |

When the AC drive is set to be Pr11-01 <Fixed Time Circulation (by time)>, the AC drive is able to run with 1 to 8 motors (the number of motor can be set by Pr11-02) while the order of running of those motors can be set by Pr11-03. To set the delay time of running of motors, use PR 11-04.

When the setting is <<03 Fixed amount control (one AC drive runs with 8 motors)>>, and if the output frequency reaches the setting of <<Pr 11-06 Motor Switch Frequency during the Fixed Amount Circulation>> and surpasses (or is equal to) the setting of <<Pr 11-05 Motor Switch Delay Time during the Fixed Amount Circulation>>, the AC drive will start to run a second motor. The AC drive is able to run up to 8 motors in order and simultaneously (the number of motors can be set by <<Pr11-02>>). When output frequency is lower than the output frequency of <<Pr 11-11>>, the motors will stop running one by one.

When the setting is <04 Fixed Time Switch and Fixed Amount Circulation>, its function is the same as fixed amount circulation. But since the Fixed Time Switch is also added, the current motor run by the AC drive will stop and start to run another idling motor. This function reduces efficiently the idling time of motors.

When the setting is <<05 Fixed Time Switch + Fixed Amount Control>>, its function is the same as Fixed Amount Control. But by adding a Fixed Switch Device will activate the auxiliary which is not in use and deactivate the one which is running. This function can prevent an auxiliary from being too long time at an idle mode.

24. Add new parameter Pr11-02: Multiple Motors Control

| | | | | |
|--------------|--------------------------------|-------|-----------------|----|
| 11-02 | Multiple Motors Control | | Factory Setting | 01 |
| | Setting Range | 01-08 | | |

25. Add new parameter Pr11-14: Delay Time when Switching Circulating Motors (2)

| | | | | |
|--------------|---|----------------|-----------------|-----|
| 11-14 | Delay Time when Switching Circulating Motors (2) | | Factory Setting | 1.0 |
| | Setting Range | 0.0-3600.0 Sec | | |

This parameter determines the delay time of switching circulating motors from mains electricity while doing fixed amount control (Pr11-01=2).

26. Add new parameter Pr11-12: Setting of Sleep Mode Function

| | | | | |
|--------------|---------------------------------------|----|-----------------------------|----|
| 11-12 | Setting of Sleep Mode Function | | Factory Setting | 00 |
| | Setting Range | 00 | Refer to PID Output Command | |
| | | 01 | Refer to Feedback signal | |

📖 When the setting is 00: the Pr11-08 is the <Sleep Frequency of Sleep Process.> while Pr11-09 is the <Wake Up Frequency of Sleep Process>

📖 When the setting is 01: the Pr11-08 is the Wake Up Feedback Frequency of Sleep Process, while Pr11-09 is the Sleep Feedback of Sleep Process.>

27. Add new parameter Pr11-08: Sleep Frequency of Sleep Process (hz)
/ Wake Up Feedback Frequency of Sleep Process (%)

| | | | | |
|--------------|--|------------|-----------------|------|
| 11-08 | Sleep Frequency of Sleep Process (hz) / Wake Up Feedback Frequency of Sleep Process (%) | | Factory Setting | 0.00 |
| | Setting Range | 0.00~11-09 | | |

📖 When Pr11-12 = 1, this parameter is a certain percentage of PID rate.

28. Add new parameter Pr11-09: Sleep Feedback rate of Sleep Process (%)

| | | | | |
|--------------|---|-------------|-----------------|------|
| 11-09 | Sleep Feedback rate of Sleep Process (%) | | Factory Setting | 0.00 |
| | Setting Range | 0.00~120.00 | | |

📖 When Pr11-12 =1, this parameter is a certain percentage of PID rate.

📖 The Sleep feedback rate of Sleep Process has to be bigger than Wake up feedback rate of Sleep Process.

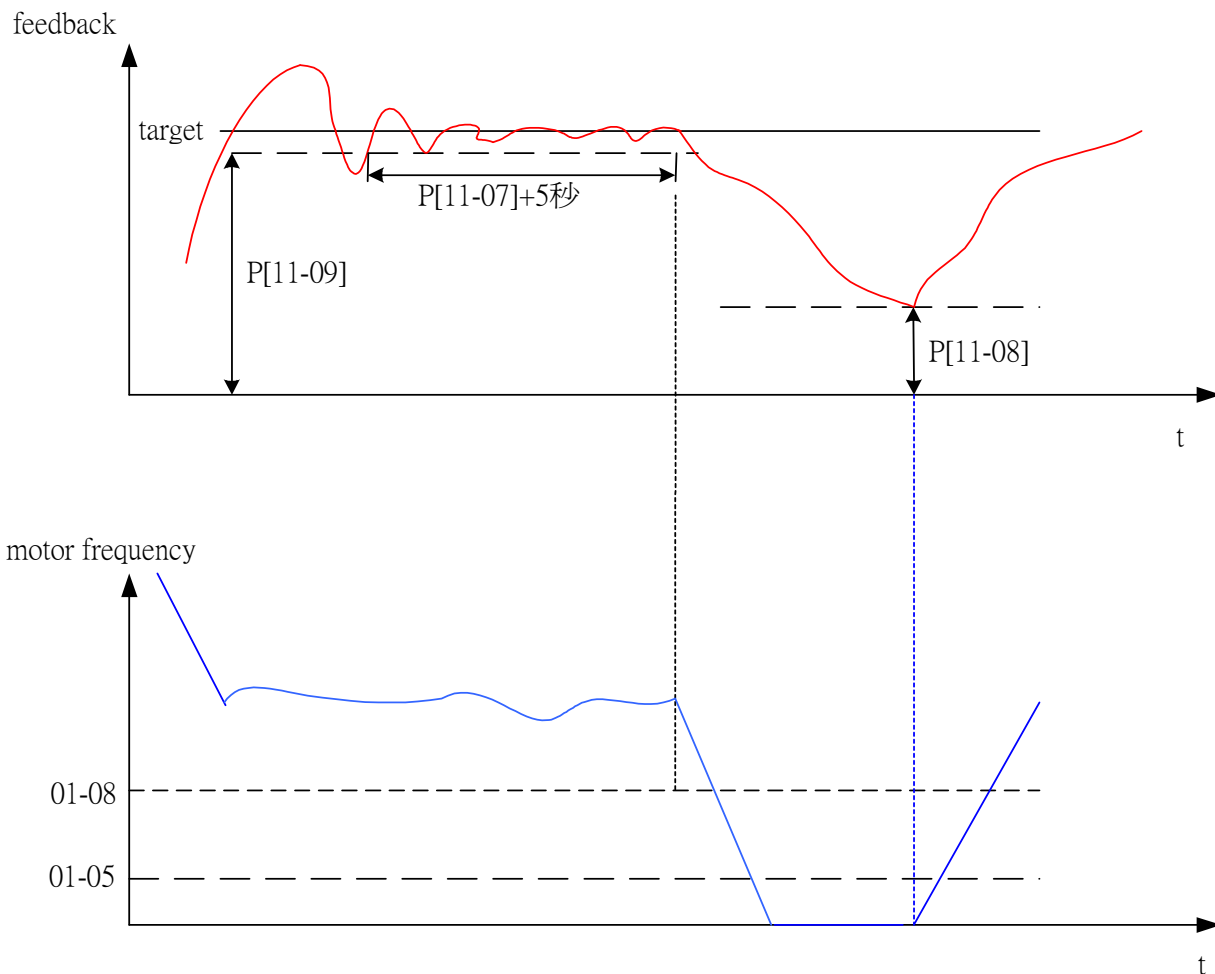

Fire Mode :

By choosing the fire mode and ignoring most of errors to make the AC drive to work non-stop could cause damages or mal function to the AC Drive and the system itself. It could even incur a fire accident. If any errors occurred by using the fire mode then lead to damages of personnels or properties, Delta Electronics Co. Ltd will not be responsible. If an AC drive is set to be at fire mode and is running under this mode, then any direct, indirect, specific or afterward damages happen to the end users or others, Delta Electronics will not be responsible for that.

could cause damages or mal function to the AC Drive, the system and the components.

Then it could lead to a fire accident or other disasters. If the AC drive is set to be the fire mode then some errors occurred to cause any mal function nor

Note:

Only under certain circumstance, the fire mode may be used to keep the motors running. For example: To keep the ventilation system running in the staircase and tunnels, Ventilation systems cannot be stopped to help the evacuation. Some errors occurred while running the fire mode will be ignored to keep the motors running unstopped.

Action time

When Pr-11-15 is not equal to zero and when external terminal MI=42 or MI=43.

 The error codes of AC drive under normal usage and fire mode.

| Code | Error Name | Normal Usage | Fire Mode |
|------|-------------------|--------------|-----------|
| 1 | OC | X | X |
| 2 | OV | X | X |
| 3 | OH | X | X |
| 4 | OL | X | |
| 5 | OL1 | X | |
| 6 | EF | X | |
| 7 | OCC | X | X |
| 8 | CF3 | X | X |
| 9 | HPF | X | X |
| 10 | OCA | X | X |
| 11 | OCN | X | X |
| 12 | OCD | X | X |
| 13 | GFF | X | X |
| 14 | LV | X | |
| 15 | CF1 | X | |
| 16 | CF2 | X | X |
| 17 | BB | X | |
| 18 | OL2 | X | |
| 20 | Code | X | |
| 21 | EF1 | X | |
| 22 | PHL | X | |
| 23 | Lc | X | |
| 24 | FbL | X | |
| 26 | FANP | X | |
| 27 | Fan1 Abnormal | X | |
| 28 | Fan2 Abnormal | X | |
| 29 | Fan3 Abnormal | X | |
| 30 | Fan1,2,3 Abnormal | X | |
| 31 | Fan1,2 Abnormal | X | |
| 32 | Fan1,3 Abnormal | X | |
| 33 | Fan2,3 Abnormal | X | |
| 34 | FV | X | X |
| 41 | HPF1 | X | X |
| 42 | HPF2 | X | X |
| 43 | HPF3 | X | X |
| 44 | HPF4 | X | X |
| 45 | CF33 | X | X |
| 46 | CF34 | X | X |
| 47 | CF35 | X | X |
| 48 | CF36 | X | X |
| 49 | CF37 | X | X |
| 50 | CF38 | X | X |

29. Add new parameter Pr11-13: Reserved

| | | | |
|--------------|-----------------|-----------------|----|
| 11-13 | Reserved | Factory Setting | 00 |
| | Setting Range | Reserved | |

 This parameter determines the largest PID Integral rate when waking up. If the integral rate is too big, the AC drive will be easily overcharges. If the integral rage is too small, the AC drive will react slowly.

30. Add new parameter Pr11-15: Fire Mode Function

| | | | | |
|--------------|---------------------------|---|-----------------|---|
| 11-15 | Fire Mode Function | ⚡ | Factory Setting | 0 |
| | Setting Range | | | |
| | 00 | Turn off Fire Mode Function | | |
| | 01 | To turn at Clock-wise direction | | |
| | 02 | To turn at counter clock-wise direction | | |

 This parameter determines to turn on or off the Fire mode function and the direction of fire mode.

31. Add new parameter Pr11-16: Operation Frequency at Fire Mode

| | | | | |
|--------------|---|--------|-----------------|-------|
| 11-16 | Operation Frequency at Fire Mode | ⚡ | Factory Setting | 60.00 |
| | Setting Range | 0~FMAX | | |

 This parameter determines the operation frequency at fire mode.

32. Add new parameter Pr11-17: umber of Times to Re-activate while Abnormal Fire Mode

| | | | |
|--------------|--|-----------------|---|
| 11-17 | Number of Times to Re-activate while Abnormal Fire Mode | Factory Setting | 0 |
| | Setting Range | 0~10 | |

 This parameter determines the number of times to re-activate the system while abnormal fire mode.

 Able to re-activate while abnormal fire mode: OC、OV、OH、OCC、OCA、OCN、OCD、GFF、FV。

 This parameter is only effective when bypass mode is already set up. If bypass mode is not set up, then the AC drive will always be reset.

33. Add new parameter Pr11-18: Bypass Function

| | | | |
|--------------|------------------------|-----------------|----|
| 11-18 | Bypass Function | Factory Setting | 00 |
| | Setting Range | | |
| | 00 | Turn Off | |
| | 01 | Turn On | |

- 📖 This parameter determines to turn on or turn off the bypass function. AC drive can switch to operate under this function by using this function.
- 📖 The abnormal codes are to activate bypass function under the fire mode. OC、OV、OH、OCC、CF3、HPF、OCA、OCN、OCD、GFF、PHL、FV。

34. Add new parameter Pr11-19: Bypass Delay time under Fire Mode

| | | | |
|--------------|--|-------------------|-----|
| 11-19 | Bypass Delay time under Fire Mode | Factory Setting | 0.0 |
| | Setting Range | 0.0~6550.0 Second | |

- 📖 This parameter determines the bypass delay time.
- 📖 When the external bypass actuation timing starts, the inverter stops any output.
- 📖 External bypass actuation timing
When error codes such as CF3, HPF are shown on the inverter, wait for command of Pr11-19<Bypass delay time under fire mode> then the bypass will actuate.

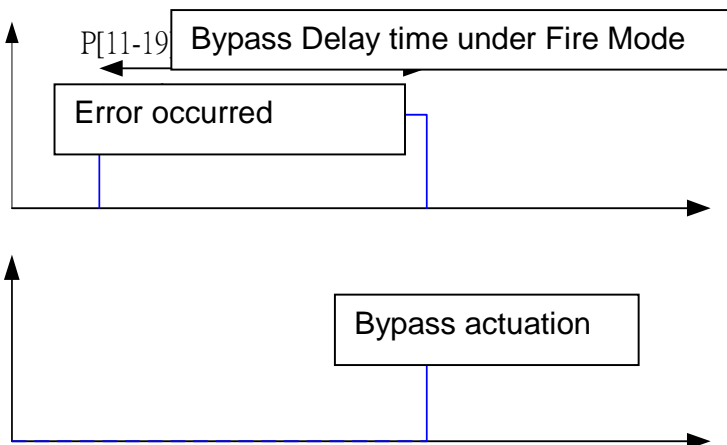

External bypass actuation timing

When error codes are not eliminated (i.e. OC, OV, OH, OCC, OCA, OCD, OCN, GFF and FV) and when Pr11-19<Bypass delay time under fire mode> arrives.

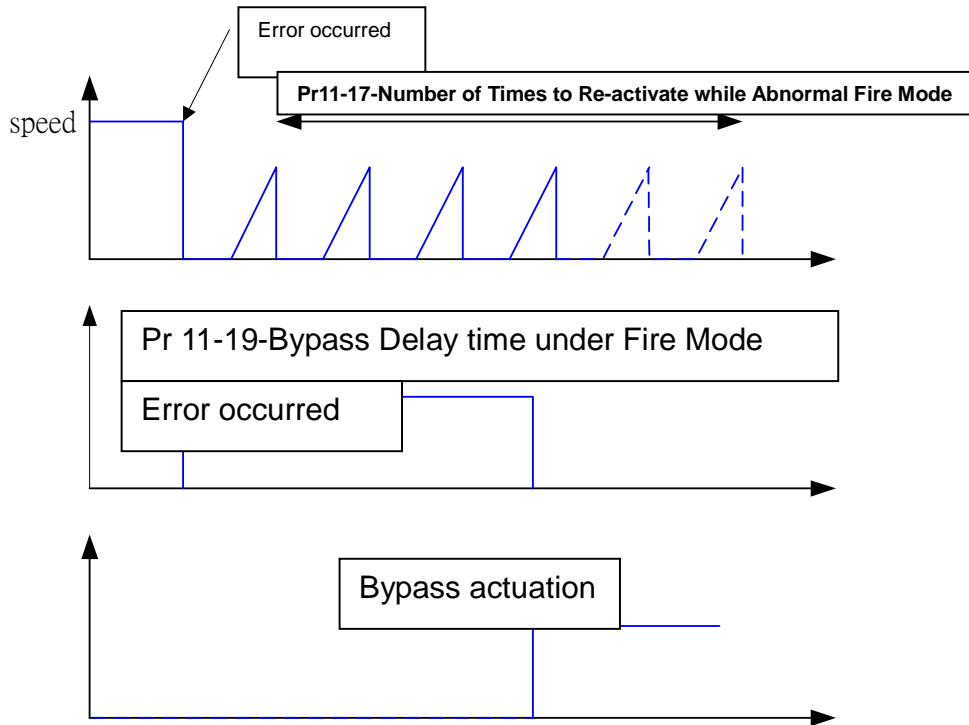

External bypass Actuation Timing

Under the fire mode, the number of time of autorestart is ZERO for the following error code: OC, OV, OH, OCC, OCA, OCD, OCN, GFF.

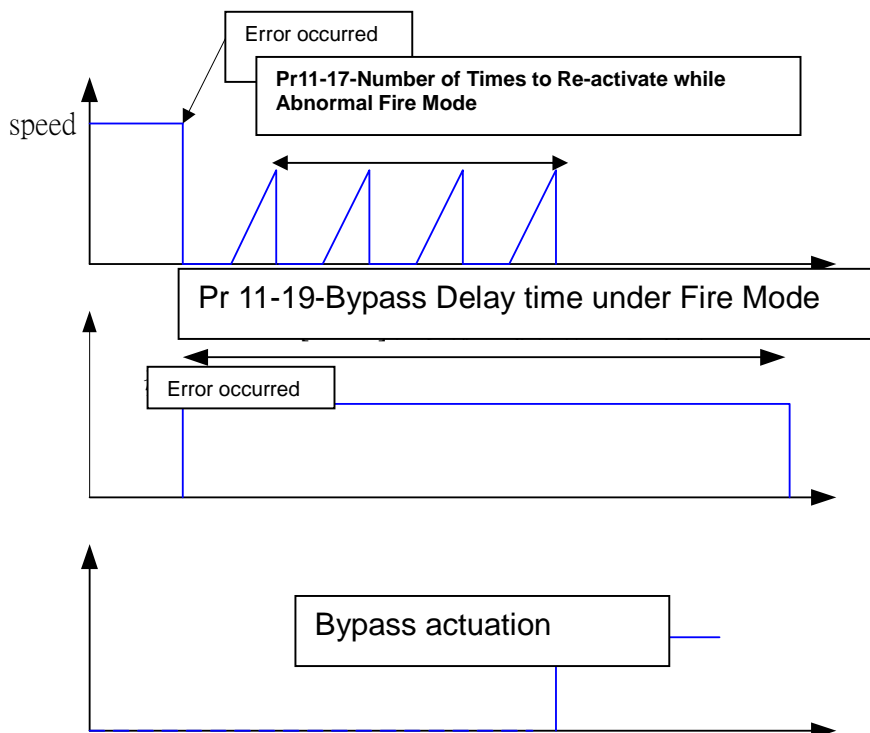

Additional information on Circulative Control

Pr11-01=01 : Fixed Time Circulation

After Motor#1 follows Pr11-03 <Fixed Time Circulation Setting> to run for some time, it will park freely. Then Motor # 2 will wait for the Pr11-04<Motor Switch Delay Time> and start to run. The order to run of fixed time circulation is Motor1-Motor2-Motor3-Motor4-Motor1-Motor2-Motor3-Motor4 repeatedly.

- Setting of Related Parameters :

- Pr11-01=01 Select <Fixed Time Circulation>
- Pr11-02=X Set quantity of motors, maximum 8 motors.
- Pr11-03=X Set time for fixed time circulation.
- Pr11-04=X Set time for motor switch delay time.

Multi-function output terminal will follow Pr11-02 for setting.

| Pr11-02= | 01 | 02 | 03 | 04 | 05 | 06 | 07 | 08 |
|----------|----|----|----|----|----|----|----|----|
| Pr03-00= | 1 | 1 | 1 | 1 | 1 | 1 | 1 | 1 |
| Pr03-01= | - | 2 | 2 | 2 | 2 | 2 | 2 | 2 |
| Pr03-02= | - | - | 3 | 3 | 3 | 3 | 3 | 3 |
| Pr03-03= | - | - | - | 4 | 4 | 4 | 4 | 4 |
| Pr03-04= | - | - | - | - | 5 | 5 | 5 | 5 |
| Pr03-05= | - | - | - | - | - | 6 | 6 | 6 |
| Pr03-06= | - | - | - | - | - | - | 7 | 7 |
| Pr03-07= | - | - | - | - | - | - | - | 8 |

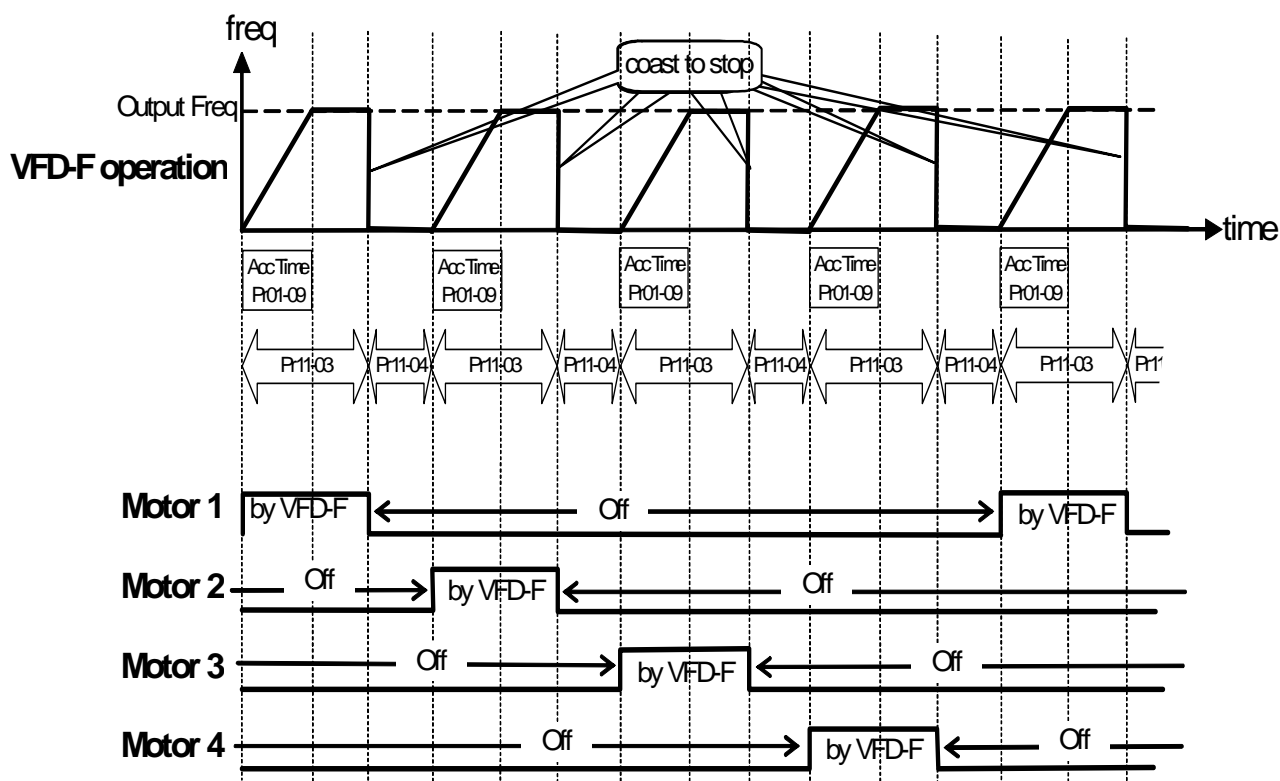

Description of Fixed Time Circulation

● Example of Fixed Time Circulation: Connecting 4 Motors

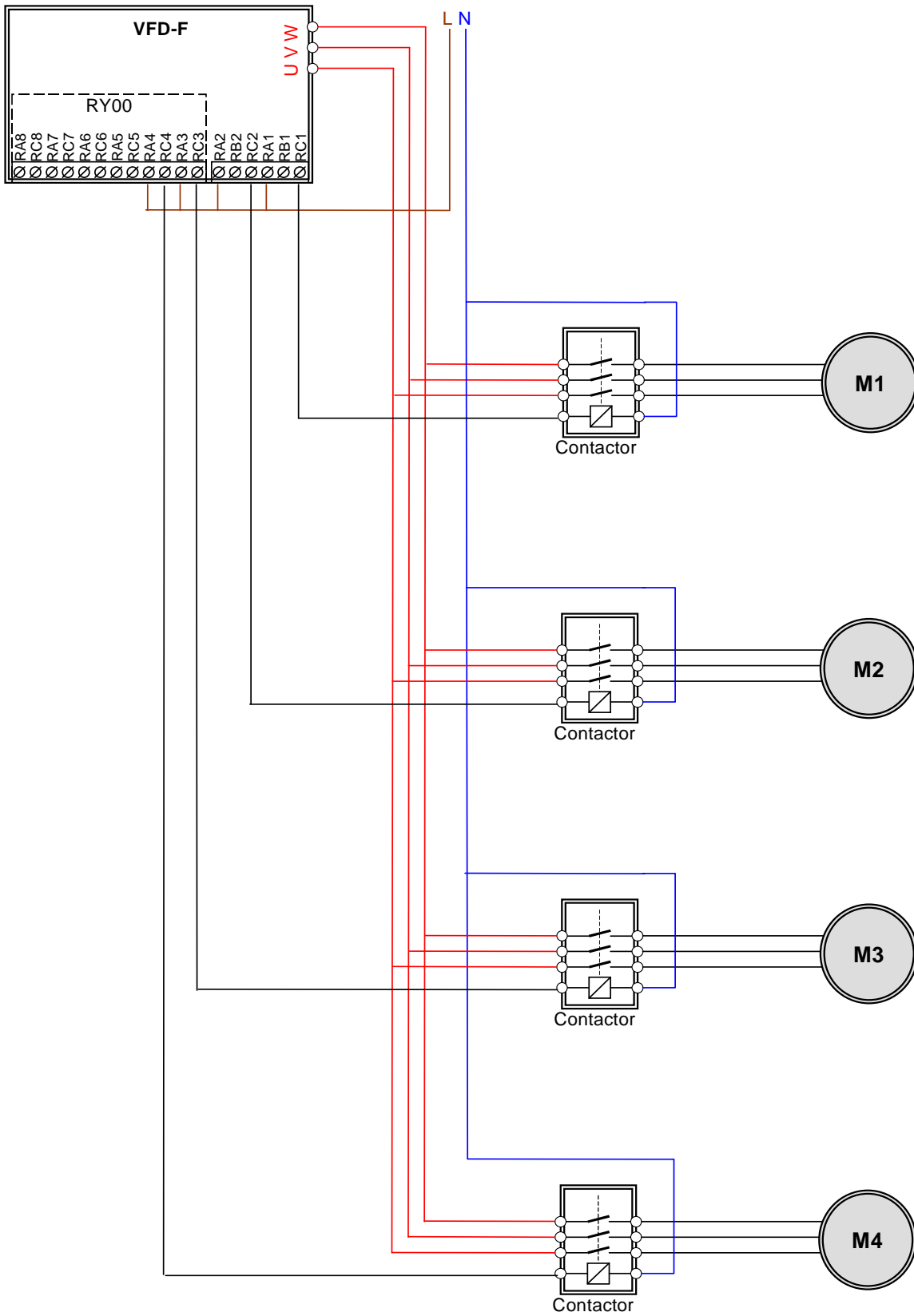

Pr11-01=02 : Fixed Amount Circulation

When Motor#1 of the inverter accelerate from 0Hz to the highest frequency, it will follow Pr11-05<Motor switch delay time during Fixed Amount Circulation> to decelerate. After the time set by Pr11-04<Motor Switch Delay Time>, Motor01 will not be powered by the inverter but by the mains. Then after the same length of time set by Pr11-04<Motor Switch Delay Time>, Motor#2 will be powered by the inverter, so on and so forth. Please refer to the Increasing Demand graph.

When Motor#4 which is powered by the inverter decreases from the largest frequency to 0Hz and after it runs for the length of time set by Pr11-14, it will make one of the motor not to be powered by the mains electricity. Then after it runs again for the same length of time set by Pr11-14, it will stop another motor being powered by the mains electricity, so on and so forth. Please refer to the Decreasing demand graph. No matter it is the acceleration or the deceleration, the 4 motors will be running at this order repeatedly: 1-2-3-4-1-2-3-4

- Setting of Related Parameters

Pr11-01=02 Select <Fixed Amount Circulation>.

Pr11-02=X Set quantity of motors, maximum 4.

Pr11-05=X Set motor switch delay time

Pr11-06=X Activation Frequency of an Auxiliary

Pr11-04=X Command from the AC drive to increase the motor switch delay time (Please refer to Increasing demand graph)

Pr11-14=X Command from the AC drive to decrease the motor switch delay time (Please refer to the Decreasing demand graph).

Multi-function output terminal will follow Pr11-02 for setting.

| Pr11-02= | 01 | 02 | 03 | 04 | |
|----------|----|----|----|----|-------------------|
| Pr03-00= | 1 | 1 | 1 | 1 | Motor #1 by VFD-F |
| Pr03-01= | 2 | 2 | 2 | 2 | Motor #1 on Mains |
| Pr03-02= | - | 3 | 3 | 3 | Motor #2 by VFD-F |
| Pr03-03= | - | 4 | 4 | 4 | Motor #2 on Mains |
| Pr03-04= | - | - | 5 | 5 | Motor #3 by VFD-F |
| Pr03-05= | - | - | 6 | 6 | Motor #3 on Mains |
| Pr03-06= | - | - | - | 7 | Motor #4 by VFD-F |
| Pr03-07= | - | - | - | 8 | Motor #4 on Mains |

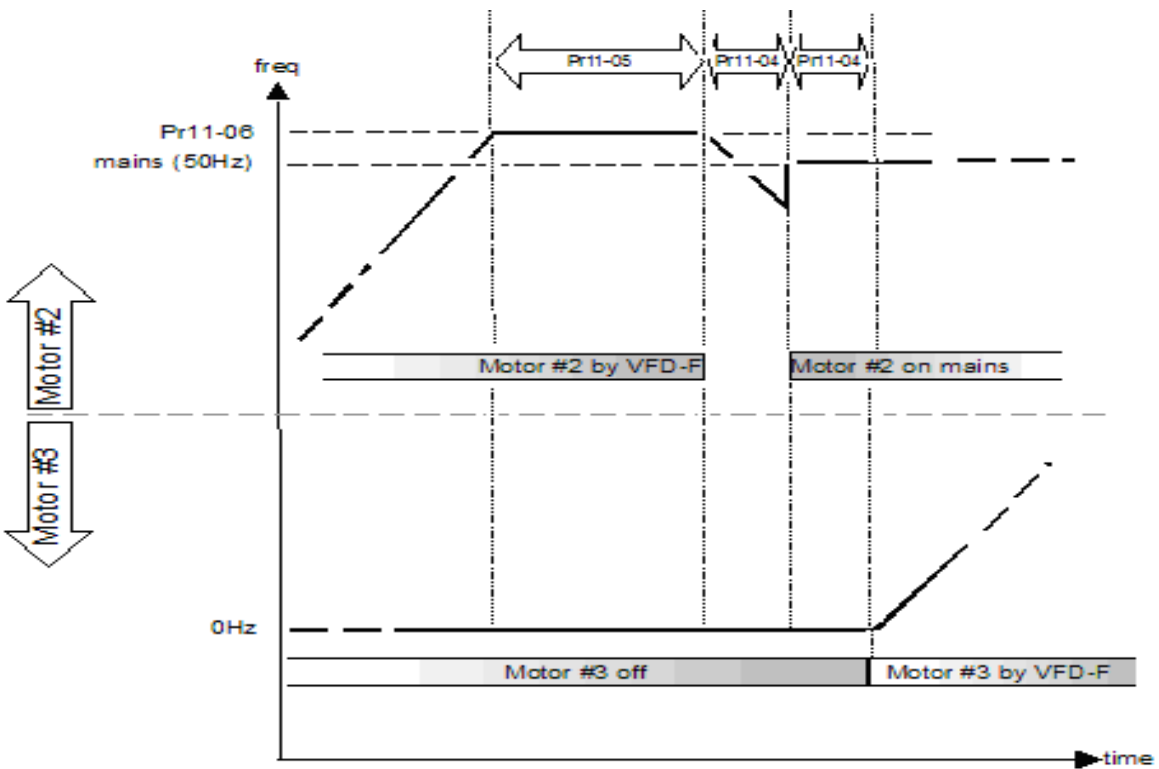
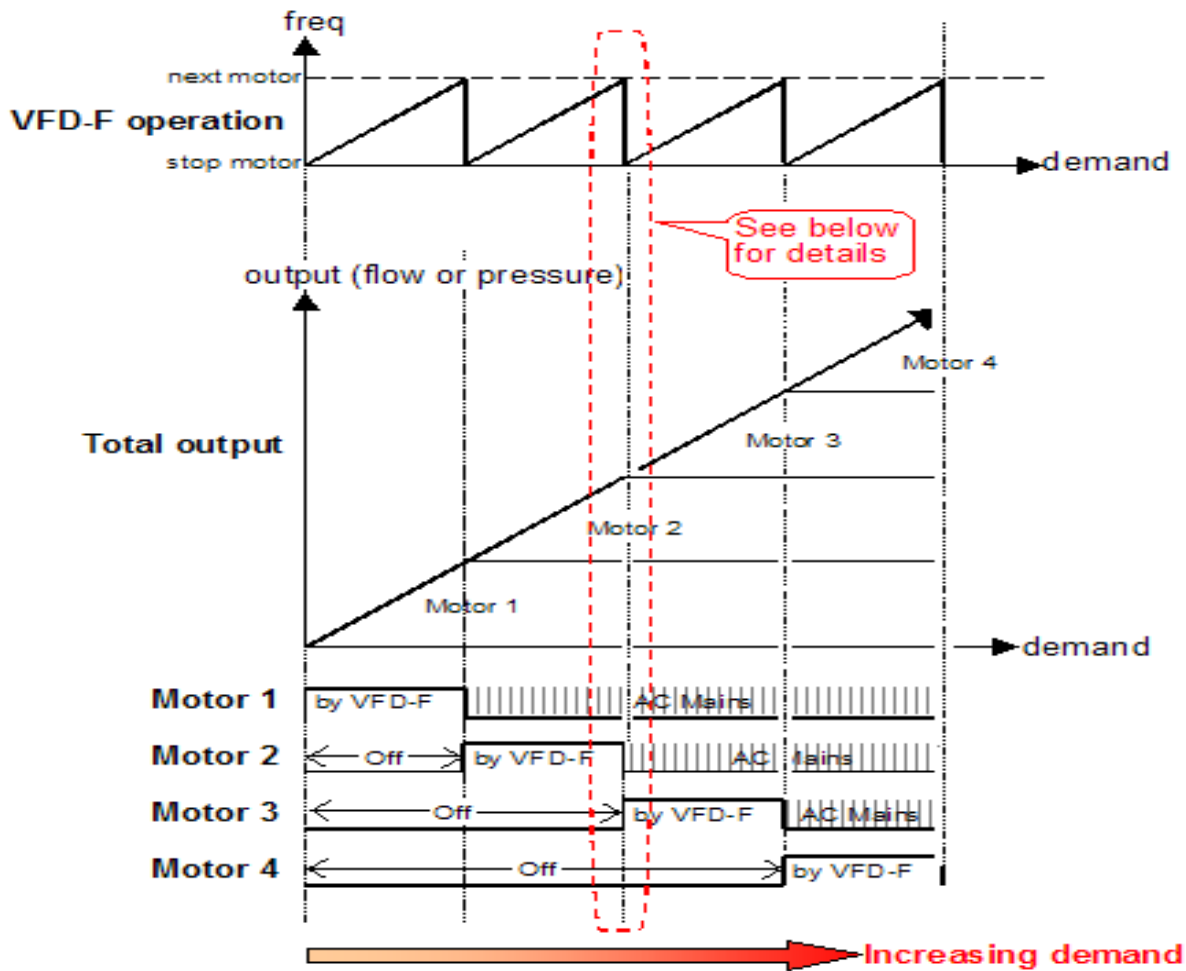

Graph: Increasing Demand

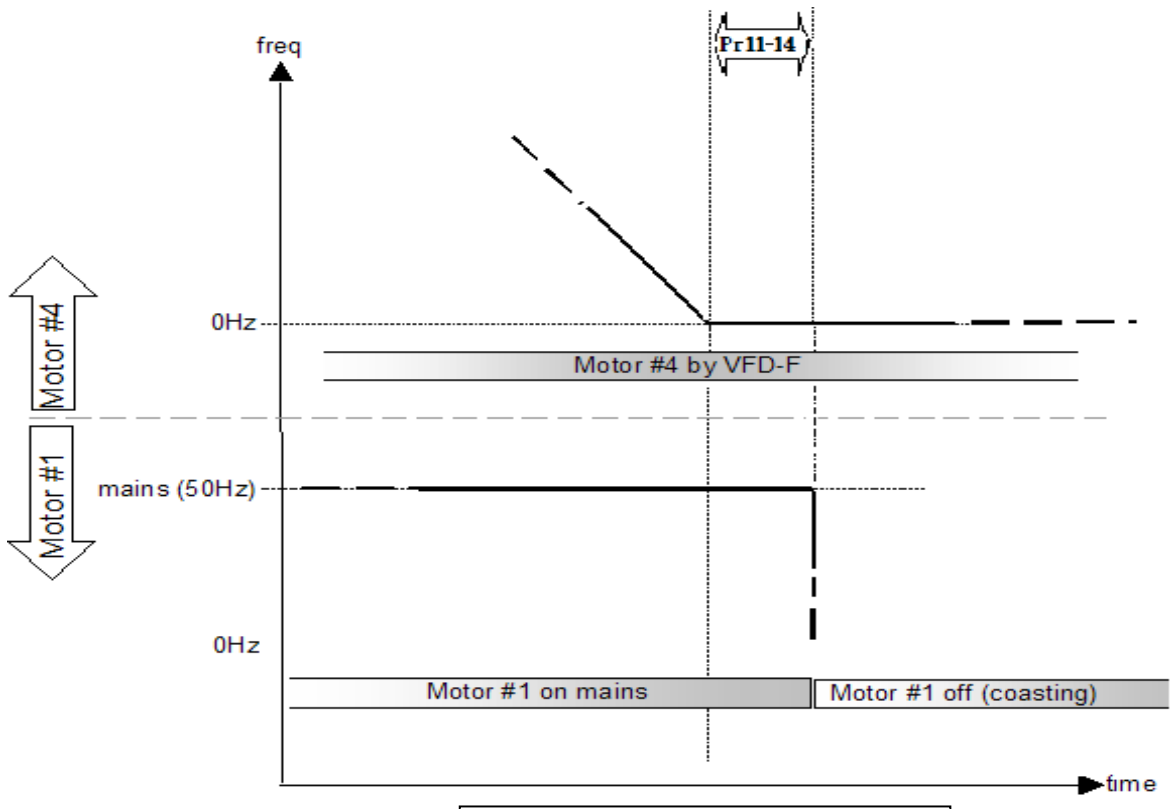
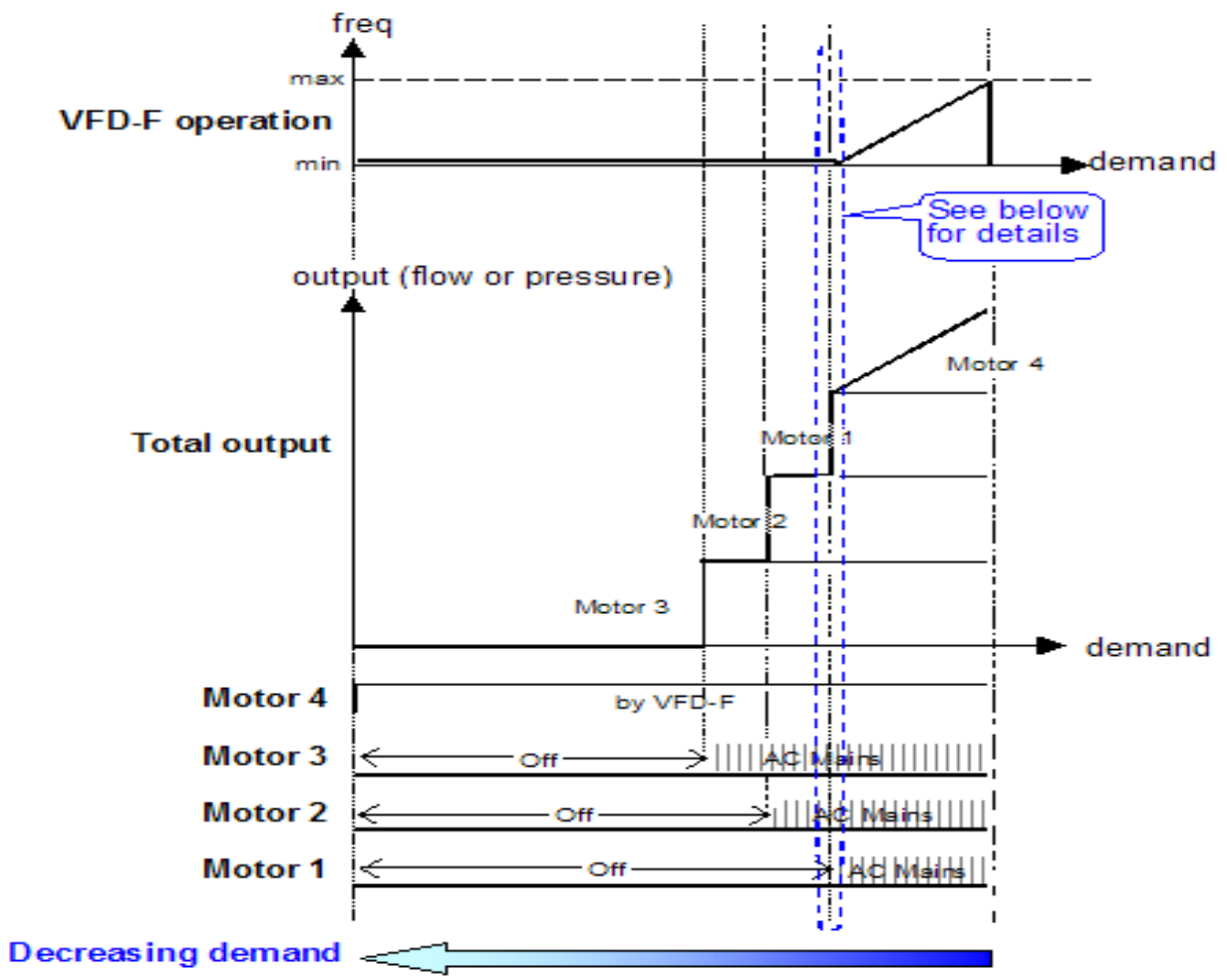

Graph: Decreasing Demand

● Example of Fixed Amount Circulation: Connecting to 4 motors

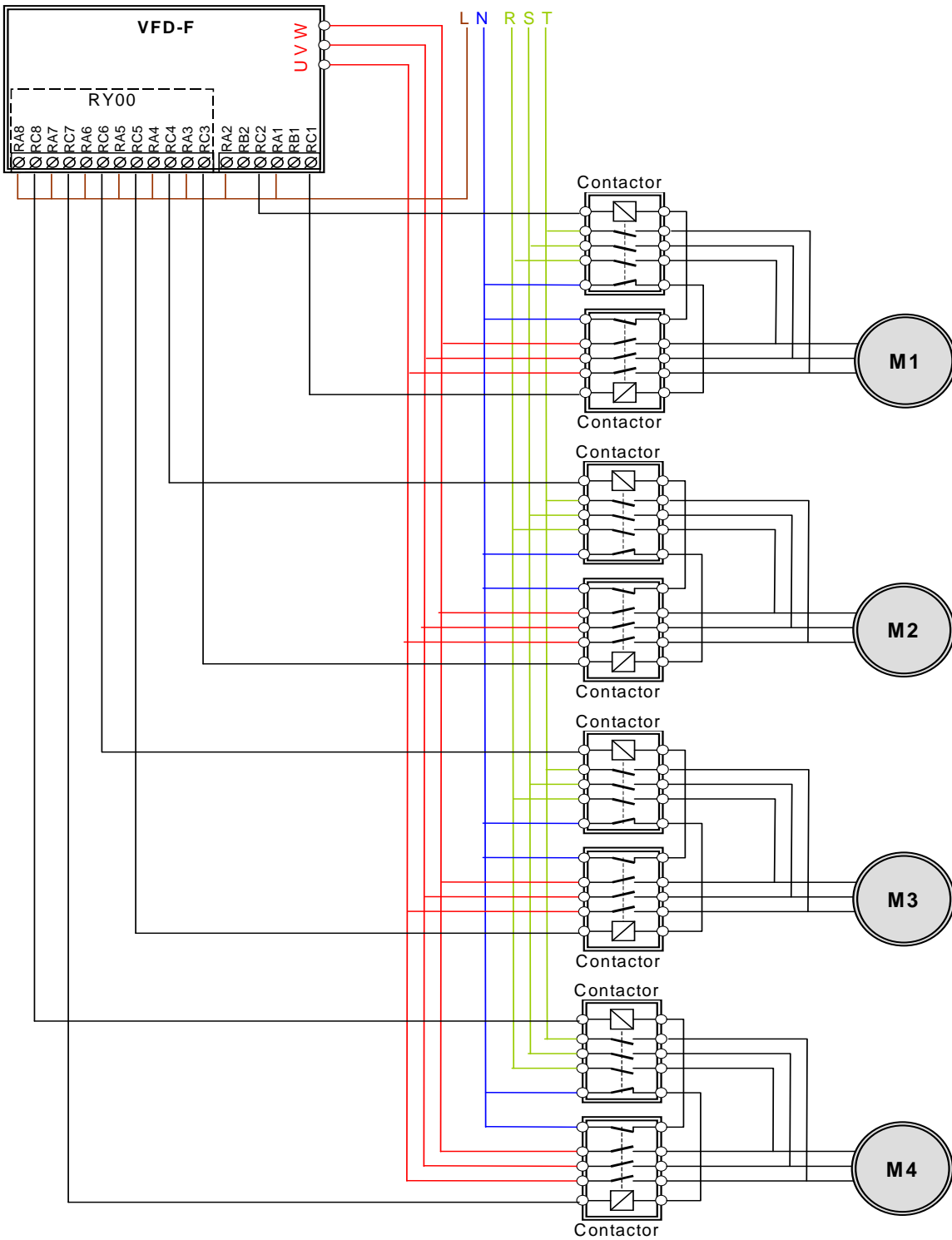

Pr11-01=03 : Fixed Amount Control

The motor powered by the inverter accelerates from 0Hz to exceed the frequency value set at Pr11-06. Then after the inverter runs for the length of time set at Pr11-05, it will pass Auxiliary#1 to be powered by the mains electricity. Then it will pass other auxiliaries to be powered by the main electricity in the same way. (Please refer to Increasing Demand graph)

The motor powered by the inverter decelerates from its largest frequency to 0Hz. Then when it passes the length of time set at Pr11-05, it will stop Auxiliary#1 being powered by the mains electricity. It will continue to stop repeatedly other auxiliaries being powered by the mains electricity one by one in the following order: 1-2-3-4-1-2-3-4.

- Setting of related Parameters

Pr11-01=01 Select fixed time circulation

Pr11-02=X Set quantity of motors, maximum 8 motors.

Pr11-05=X Delay time to activate auxiliaries.

Pr11-06=X Activation frequency of auxiliaries

Multi-function output terminals follow automatically the settings of Pr11-02

| Pr11-02= | 01 | 02 | 03 | 04 | 05 | 06 | 07 | 08 | |
|----------|----|----|----|----|----|----|----|----|------------------|
| Pr03-00= | 1 | 1 | 1 | 1 | 1 | 1 | 1 | 1 | Motor#1 on Mains |
| Pr03-01= | - | 2 | 2 | 2 | 2 | 2 | 2 | 2 | Motor#2 on Mains |
| Pr03-02= | - | - | 3 | 3 | 3 | 3 | 3 | 3 | Motor#3 on Mains |
| Pr03-03= | - | - | - | 4 | 4 | 4 | 4 | 4 | Motor#4 on Mains |
| Pr03-04= | - | - | - | - | 5 | 5 | 5 | 5 | Motor#5 on Mains |
| Pr03-05= | - | - | - | - | - | 6 | 6 | 6 | Motor#6 on Mains |
| Pr03-06= | - | - | - | - | - | - | 7 | 7 | Motor#7 on Mains |
| Pr03-07= | - | - | - | - | - | - | - | 8 | Motor#8 on Mains |

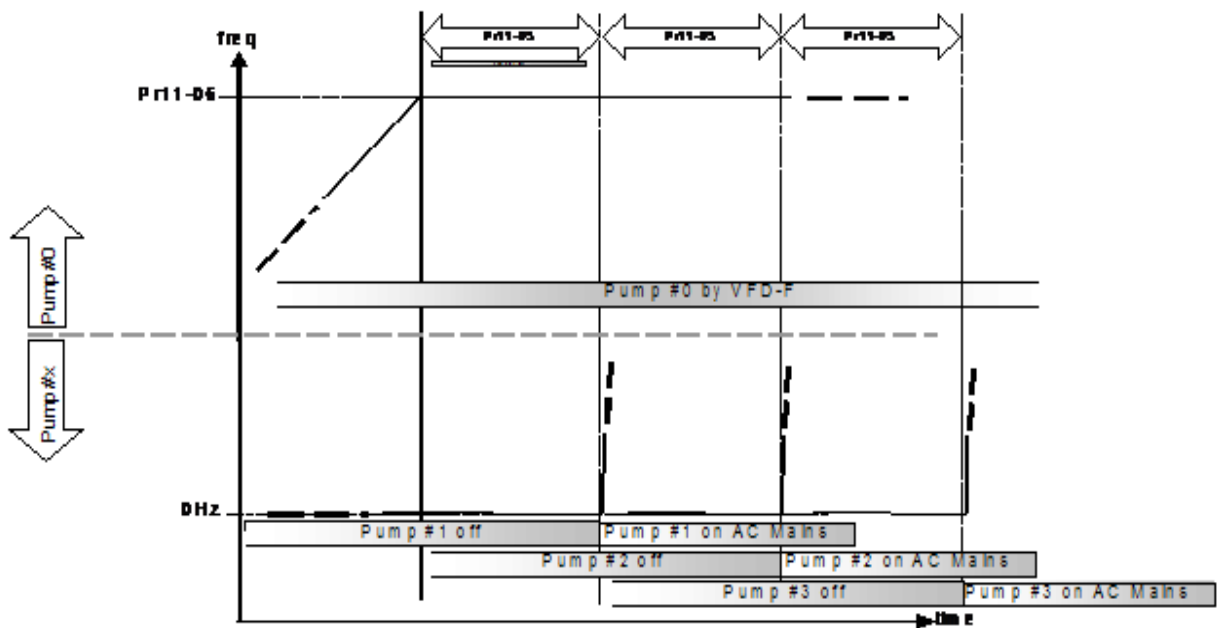
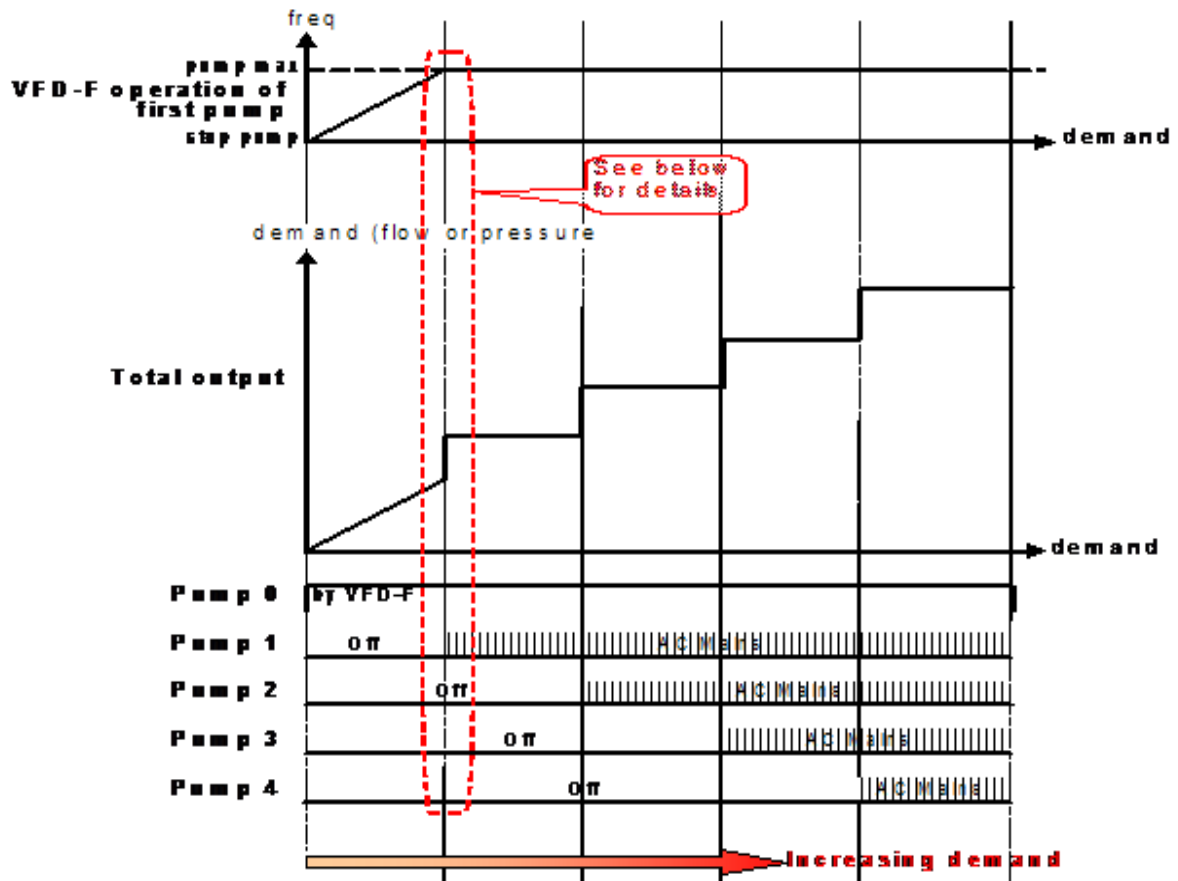

Graph: Increasing Demand

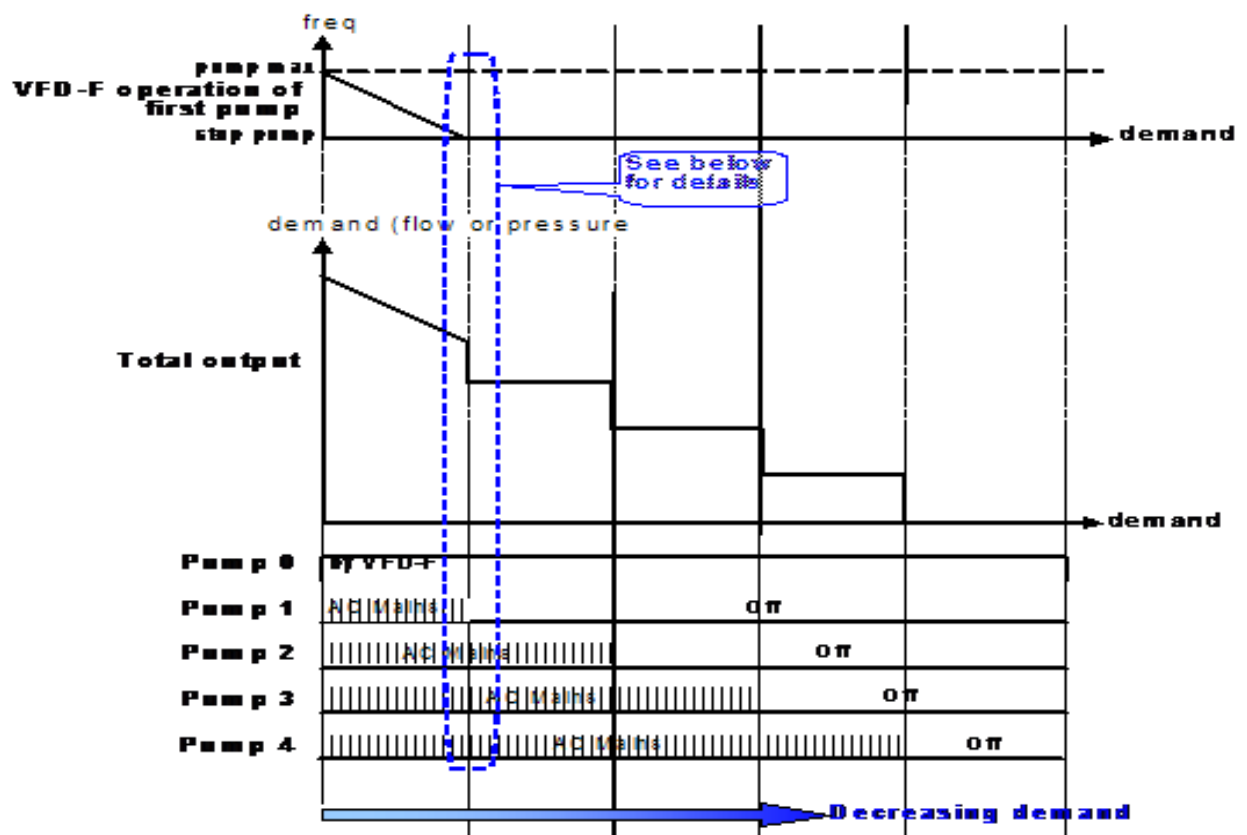

Graph: Decreasing Demand

- Example of Fixed Amount Control: Connecting to 4 motors

