

VFD-C2000



3- / 380 : 0.75~355



EN954-1, EN60204-1 IEC61508

Modbus, CANOpen, PROFIBUS-DP, DeviceNet, MODBUS TCP Ethernet/IP

(37) RFI-

(FOC)

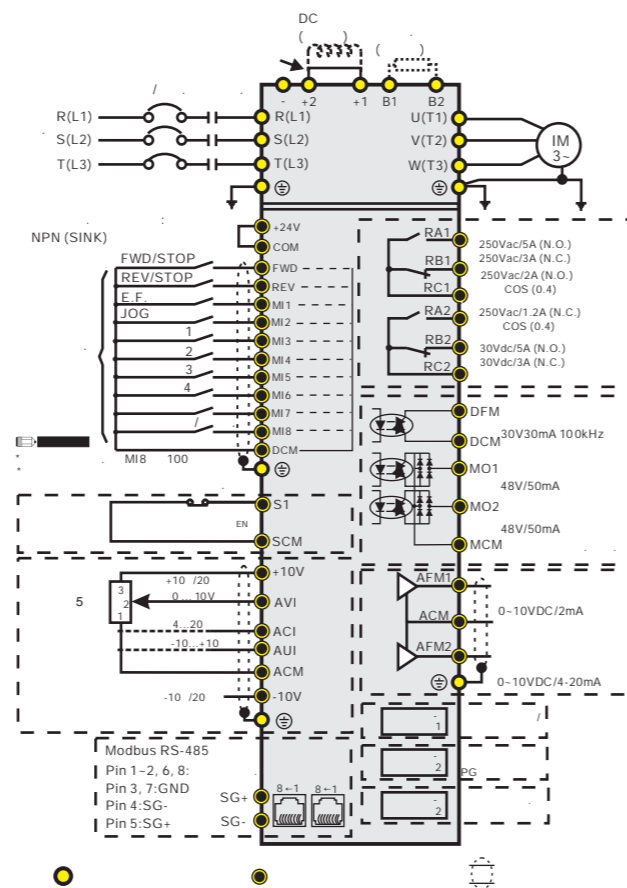

VFD-C

	1: V/F, 2: SVC, 3: VF+PG, 4: FOC+PG			
V/f	150%	0.5	150%	0 1
	4			
	5 (40)			
	.200%			
	+5%			
()	: 0.01~600.00 ;		: 0.00 ~ 300.00	
	: ±0.01%, -10...+40°		: ±0.1%, 25±10°	
	: 0.01		: 0.03/60 (±11)	
	: 120%		1	
	: 150%		1	
	+10...-10 , 0...10 , 4...20 , 0...20			
/	0.00...600.00/0.0...6000.0			
	, 16			
	MODBUS (RS-485 (RJ45) .115.2 /),			
	B : / ;		C :	
	: 240%			
	: 170~175%;		: 180~185%	
230:			DC	410
460:			DC	820
	20			
	: 50%			
	IEC60364-1/IEC60664-1 2,			
	NEMA 1/UL Type 1		: -10...+40°	
	2%		1° 40...60°	
	UL Open Type		: -10...+50°	
	2%		1° 50...60°	
/	-25...+70°			
	.90%			
/	.95%			
/	86 ... 106			
	70 ... 106			
	IEC60721-3-3 (application is in progress)			
	Class 3C2; Class 3S2			
	Class 2C2; Class 2S2			
	Class 1C2; Class 1S2			
	1000		1000...3000	
	2%		0.5°C 100	
/	ISTA procedure 1A() IEC60068-2-31			
1.5	, 3-13 , 1G		13-200 (IEC 60068-2-6)	
15G	11 (IEC/EN 60068 2-27)	

VFD-C

		50/60	3-				()
A	VFD007C43A/E	3-	, 380 - 480	0,75	3,0	2,9	2 ...15 130,0 250,0 170
	VFD015C43A/E	3-	, 380 - 480	1,5	4,0	3,8	
	VFD022C43A/E	3-	, 380 - 480	2,2	6,0	5,7	
	VFD037C43A/E	3-	, 380 - 480	3,7	9,0	8,1	
	VFD040C43A/E	3-	, 380 - 480	4,0	10,5	9,5	
	VFD055C43A/E	3-	, 380 - 480	5,5	12,0	11,0	
B	VFD075C43A/E	3-	, 380 - 480	7,5	18,0	17,0	2 ...15 190,0 320,0 190,0
	VFD110C43A/E	3-	, 380 - 480	11,0	24,0	23,0	
	VFD150C43A/E	3-	, 380 - 480	15,0	32,0	30,0	
C	VFD185C43A/E	3-	, 380 - 480	18,5	38,0	36,0	2 ...10 250,0 400,0 210,0
	VFD220C43A/E	3-	, 380 - 480	22,0	45,0	43,0	
	VFD300C43A/E	3-	, 380 - 480	30,0	60,0	57,0	
D	VFD370C43A/E	3-	, 380 - 480	37	73,0	69,0	2 ...10 A: 330,0 550,0 275,0 E: 330,0 688,3 275,0
	VFD450C43A/E	3-	, 380 - 480	45	91,0	86,0	
	VFD550C43A/E	3-	, 380 - 480	55	110,0	105,0	
	VFD750C43A/E	3-	, 380 - 480	75	150,0	143,0	
E	VFD900C43A	3-	, 380 - 480	90	180,0	171,0	2 ...9 370,0 589,0 300,0
	VFD1100C43A	3-	, 380 - 480	110	220,0	209,0	
	VFD900C43E	3-	, 380 - 480	90	180,0	171,0	
	VFD1100C43E	3-	, 380 - 480	110	220,0	209,0	
F	VFD1320C43A	3-	, 380 - 480	132	260,0	247,0	2 ...9 420,0 800,0 300,0
	VFD1600C43A	3-	, 380 - 480	160	310,0	295,0	
	VFD1320C43E	3-	, 380 - 480	132	260,0	247,0	
	VFD1600C43E	3-	, 380 - 480	160	310,0	295,0	
G	VFD1850C43A	3-	, 380 - 480	185	370,0	352,0	2 ...9 550,0 1000,0 397,0
	VFD2200C43A	3-	, 380 - 480	220	460,0	437,0	
	VFD1850C43E	3-	, 380 - 480	185	370,0	352,0	
	VFD2200C43E	3-	, 380 - 480	220	460,0	437,0	
H	VFD2800C43A	3-	, 380 - 480	280	550,0	523,0	2 ...9 600,0 1390,0 398,0
	VFD3150C43A	3-	, 380 - 480	315	616,0	585,0	
	VFD3550C43A	3-	, 380 - 480	355	683,0	649,0	
	VFD2800C43E	3-	, 380 - 480	280	550,0	523,0	
	VFD3150C43E	3-	, 380 - 480	315	616,0	585,0	
VFD3550C43E	3-	, 380 - 480	355	683,0	649,0	600,0 1577,0 398,0	



EMI- "A"

MODEL:VFD007C43A

INPUT:
Normal Duty: 3PH 380-480V 50/60Hz 4.3A
Heavy Duty: 3PH 380-480V 50/60Hz 4.1A

OUTPUT:
Normal Duty: 3PH 0-480V 3A 2.4KVA 1HP
Heavy Duty: 3PH 0-480V 2.9A 2.3KVA 1HP

FREQUENCY RANGE:
Normal Duty: 0-600Hz
Heavy Duty: 0-300Hz

Version: VX.XX

007C43A7T9300002
DELTA ELECTRONICS, INC.
MADE IN XXXXXXX

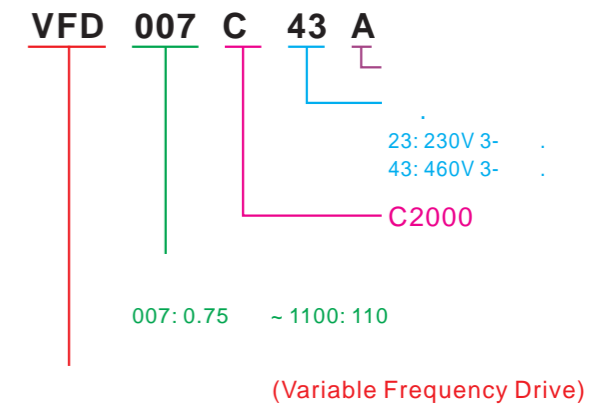

VFD-C:

CMC-EIP01 CMC-MOD01		EtherNet/IP (CMC-EIP01) MODBUS TCP (CMC-MOD01) 10/100 / ,
CMC-PD01		DP-PROFIBUS 9.6 / , 19.2 / , 96.75 / , 187.5 / , 500 / , 1.5 / , 3 / , 6 / 12 /
CMC-DN01		DeviceNet 125 / , 250 / , 500 /
EMC-COP01		CANopen 1 500k 250k 125k 100k 50k
EMC-R6AA		(6)
EMC-D42A		(4 2 /)
EMC-D611A		(6)
EMC-PG01O EMC-PG01L EMC-PG01U EMC-PG01R		PG (1-255) : 300
KPC-CE01		7- LED- (MKC-KPPK) , IP56.

VFD-E

V/F

(PLC)

1- / 220 : 0.2~2.2
3- / 380 : 0.4~22



MODBUS (38400 /),
Profibus DP, DeviceNet, LonWorks, CANopen

DC BUS
RoHS

(PTC-)

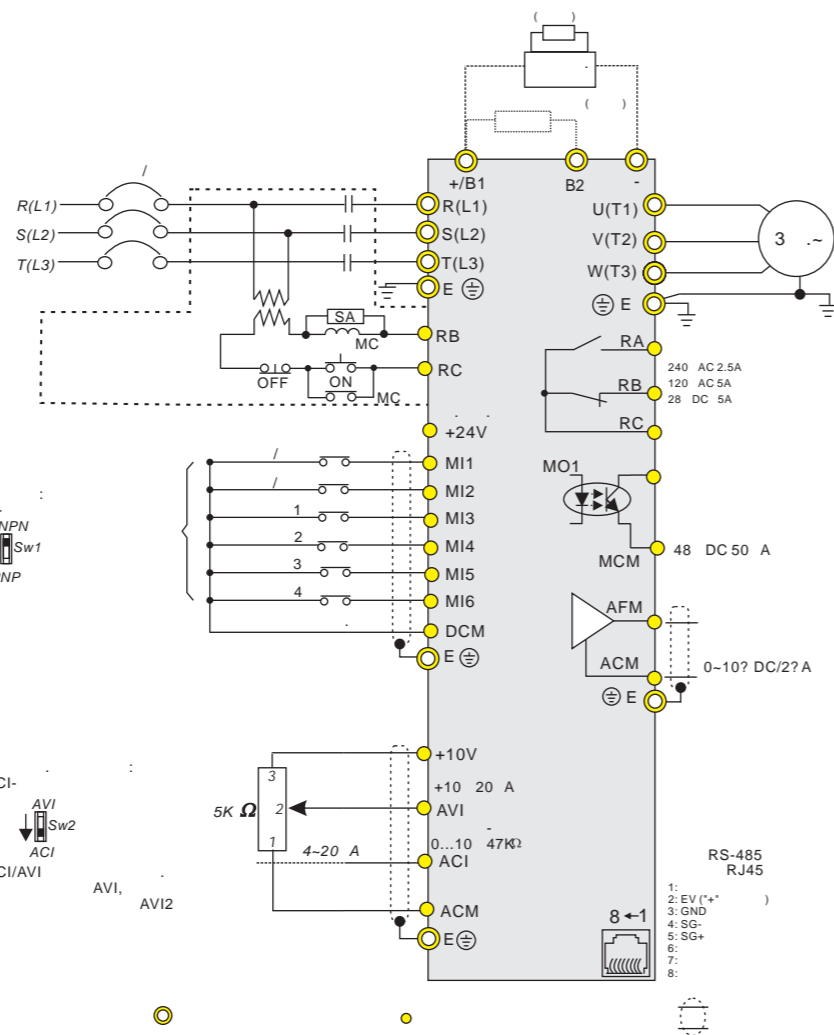

VFD-E

	50/60	3-		()	
VFD002E21A	1- , 200 - 240	0,2	1,6	72,0 142,0 152,0	1,1
VFD004E21A	1- , 200 - 240	0,4	2,5	72,0 142,0 152,0	1,1
VFD004E43A	3- , 380 - 480		1,5	72,0 142,0 152,0	1,2
VFD007E21A	1- , 200 - 240	0,75	4,2	72,0 142,0 152,0	1,1
VFD007E43A	3- , 380 - 480		2,5	72,0 142,0 152,0	1,2
VFD015E21A	1- , 200 - 240	1,5	7,5	100,0 174,0 152,0	1,9
VFD015E43A	3- , 380 - 480		4,2	72,0 142,0 152,0	1,2
VFD022E21A	1- , 200 - 240	2,2	11,0	100,0 174,0 152,0	1,9
VFD022E43A	3- , 380 - 480		5,5	100,0 174,0 152,0	1,9
VFD037E43A	3- , 380 - 480	3,7	8,2	100,0 174,0 152,0	1,9
VFD055E43A	3- , 380 - 480	5,5	13,0	130,0 260,0 169,2	4,2
VFD075E43A	3- , 380 - 480	7,5	18,0	130,0 260,0 169,2	4,2
VFD110E43A	3- , 380 - 480	11	24,0	130,0 260,0 169,2	4,2
VFD150E43A	3- , 380 - 480	15	32,0	200,0 310,0 190,0	7,47
VFD185E43A	3- , 380 - 480	18,5	38,0	200,0 310,0 190,0	7,47
VFD220E43A	3- , 380 - 480	22	45,0	200,0 310,0 190,0	7,47

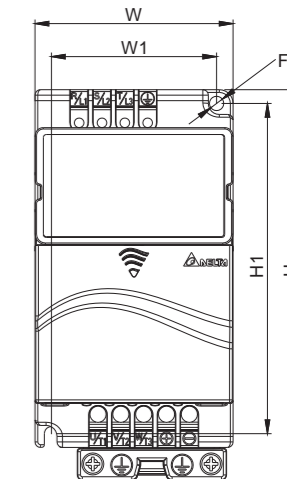

	SPWM () ; V/f
()	0.1-600 (0.01)
	; :150% 3.0
	150%
	0.1-400
/	0.1-600 (2)
	, AVR, S- / .. 5
	, NPN/PNP
	(PTC)
	IP20
	2
	1000
	-10°C ... +50°C (40°C)
	-20°C ... 60°C
	90% RH ()
	9.80665 / ² (1G) 20 , 5.88 / ² (0.6G) 20 50



VFD-E

VFD-E-P ()

- VFD002E21P (220 , 0.2)
- VFD004E21P (220 , 0.4)
- VFD004E43P (380 , 0.4)
- VFD007E21P (220 , 0.75)
- VFD007E43P (380 , 0.75)

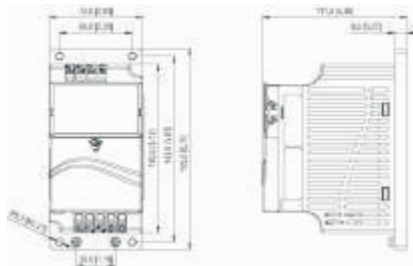

VFD-E-T ()

- VFD002E21T (220 , 0.2)
- VFD004E21T (220 , 0.4)
- VFD004E43T (380 , 0.4)
- VFD007E21T (220 , 0.75)
- VFD007E43T (380 , 0.75)
- VFD015E43T (380 , 1.5)

VFD-EL

1- / 220 : 0.2~2.2
 3- / 380 : 0.4~3.7

DIN-

V/f

RS-485 (Modbus)

B

PU06

Profibus, DeviceNet, LonWorks CANopen
 VFD PC

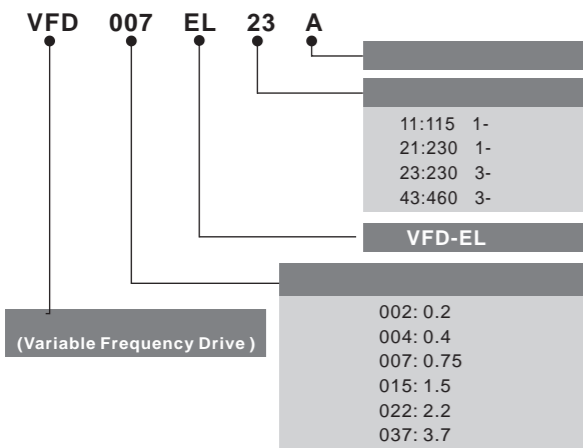
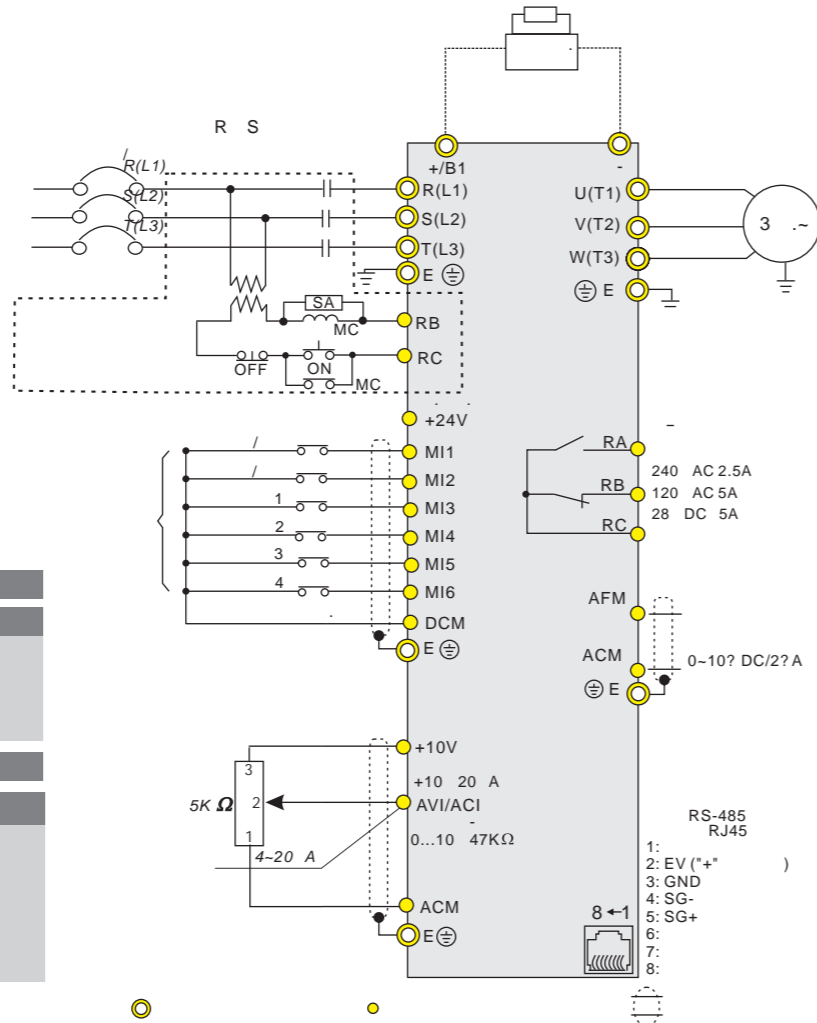

VFD-EL

	50/60	3-				
VFD002EL21A	1-	, 200 - 240	0,2	1,6	72,0 174,0 136,0	1,1
VFD004EL21A	1-	, 200 - 240	0,4	2,5	72,0 174,0 136,0	1,1
VFD004EL43A	3-	, 380 - 480		1,5	72,0 174,0 136,0	1,2
VFD007EL21A	1-	, 200 - 240	0,75	4,2	72,0 174,0 136,0	1,1
VFD007EL43A	3-	, 380 - 480		2,5	72,0 174,0 136,0	1,2
VFD015EL21A	1-	, 200 - 240	1,5	7,5	100,0 174,0 136,0	1,9
VFD015EL43A	3-	, 380 - 480		4,2	72,0 174,0 136,0	1,2
VFD022EL21A	1-	, 200 - 240	2,2	11,0	100,0 174,0 136,0	1,9
VFD022EL43A	3-	, 380 - 480		5,5	100,0 174,0 136,0	1,9
VFD037EL43A	3-	, 380 - 480	3,7	8,2	100,0 174,0 136,0	1,9

			SPWM () ; V/f			
	()		0.1-600 ()	0.01		
				0.01		
					:150% 5.0	
			150%		1	
				0.1-600		
	/		0.1-600 (2)			
			20 250%			
			: 0.1-600.0	0-60	:0-100%	0-60
				20% (125%		
	/		(V/f)			
			-5 /0.5 , 0 ... +10VDC, 4 ... 20mA,		RS-485;	Jog, up/down
			3 - 9 (15)			
			RUN STOP			
	2	/3	(FWD, REV, EF), JOG (RS-485 (MODBUS)	
			0-15, Jog,	/	/	.2,
			(NC, NO),	ACI/AVI,	(UP/DOWN),	NPN/PNP
						(NC/NO)
			AVR, S-	(1	1	5
			MODBUS,			
						NPN/PNP
						(PTC)
	6-	,4		7-	4-	LED-
						RUN, STOP, RESET, FWD/REV, JOG
						IP20
						2
			1000			
			-10°C ... +50°C (40°C			
						-20°C ... 60°C
						90% RH ()
						9.80665 / ² (1G) 20 ,5.88 / ² (0.6G) 20 50

VFD-F

: 0.1~120
 V/F
 ()
 15
 132 - 220
 18.5 - 160
 185 - 220
 MODBUS (38400 /),
 Profibus DP, DeviceNet, LonWorks

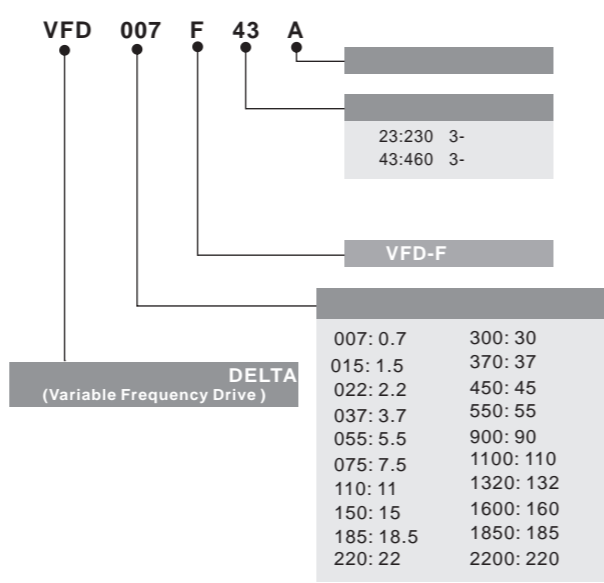
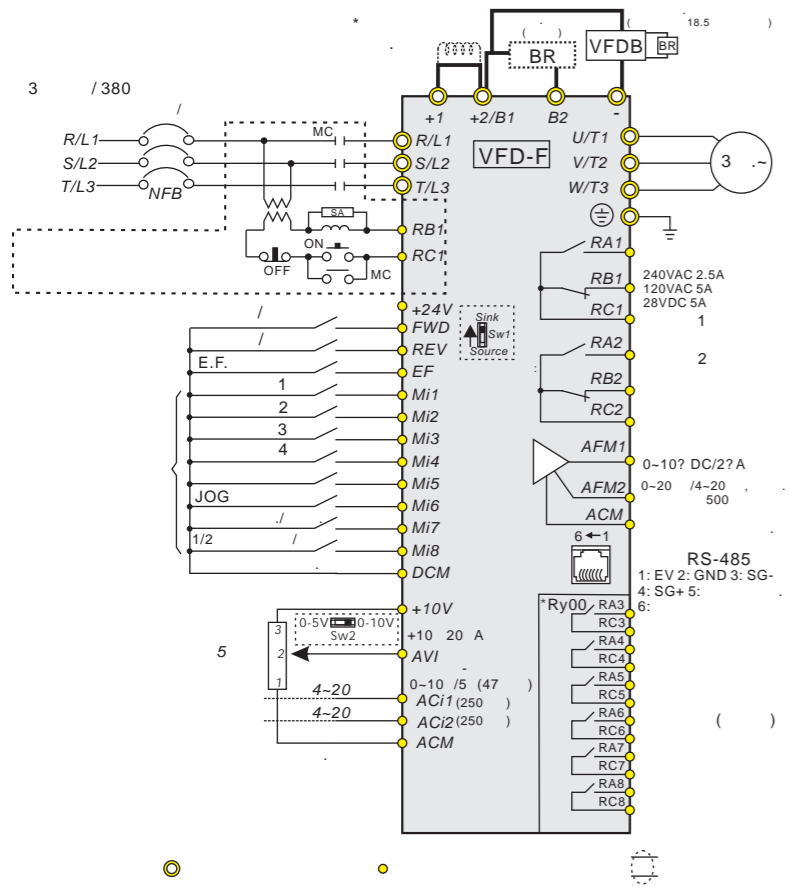

VFD-F

	50/60	3-		()
VFD007F43A		0,75	2,7	150,0 260,0 160,2
VFD015F43A		1,5	4,2	150,0 260,0 160,2
VFD022F43A		2,2	5,5	150,0 260,0 160,2
VFD037F43A		3,7	8,5	150,0 260,0 160,2
VFD055F43B		5,5	13,0	200,0 323,0 183,2
VFD075F43B		7,5	18,0	200,0 323,0 183,2
VFD110F43A		11,0	24,0	200,0 323,0 183,2
VFD150F43A		15,0	32,0	200,0 323,0 183,2
VFD185F43A		18,5	38,0	250,0 403,0 205,4
VFD220F43A		22,0	45,0	250,0 403,0 205,4
VFD300F43A		30,0	60,0	250,0 403,0 205,4
VFD370F43A	3-	37,0	73,0	370,0 589,0 260,0
VFD450F43A		45,0	91,0	370,0 589,0 260,0
VFD550F43A		55,0	110,0	370,0 589,0 260,0
VFD750F43A		75,0	150,0	370,0 595,0 260,0
VFD900F43C		90,0	180,0	370,0 595,0 260,0
VFD1100F43C		110,0	220,0	425,0 850,0 264,0
VFD1320F43A		132,0	260,0	425,0 850,0 264,0
VFD1600F43A		160,0	310,0	425,0 850,0 264,0
VFD1850F43A		185,0	370,0	547,0 1357,6 360,0
VFD2200F43A		220,0	460,0	547,0 1357,6 360,0

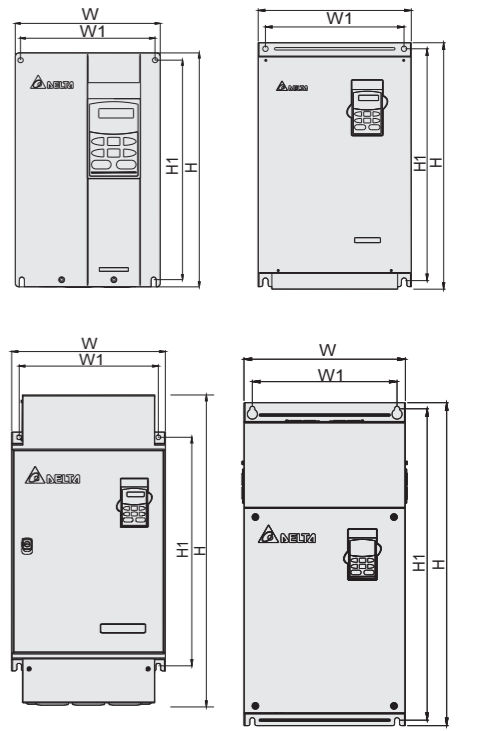

	SPWM () ; V/f
()	0.1~120 (0.01)
	: 150% 1
	120%
	0.1~120
/	1-3600/0.1-3600.0/0.01-360.00 (3)
	20 250%
	: 0.1~120 .0 , : 0~100 % : 0~60 , 0~60
/ - (V/f)	.20% (125% . 0.75-15)
	AVR, S-
	MODBUS,
	, NPN/PNP
	8- , 5- , 7- , 5- . LED-
	, RUN, STOP, RESET, FWD/REV, JOG
	IP 20
	2
	1000
	-10°C... +40°C
/	-20°C ... +60°C
	90% RH ()
	9.80665 / ² (1G) 20 , 5.88 / ² (0.6G) 20 50

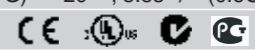

VFD-G

: 150% 60
 (5.5 -90 F>15)
 (IGBT)
 : 0.1-120
 15
 (18.5 -132)
 2 160-220 (1A)
 MODBUS (38400 /)

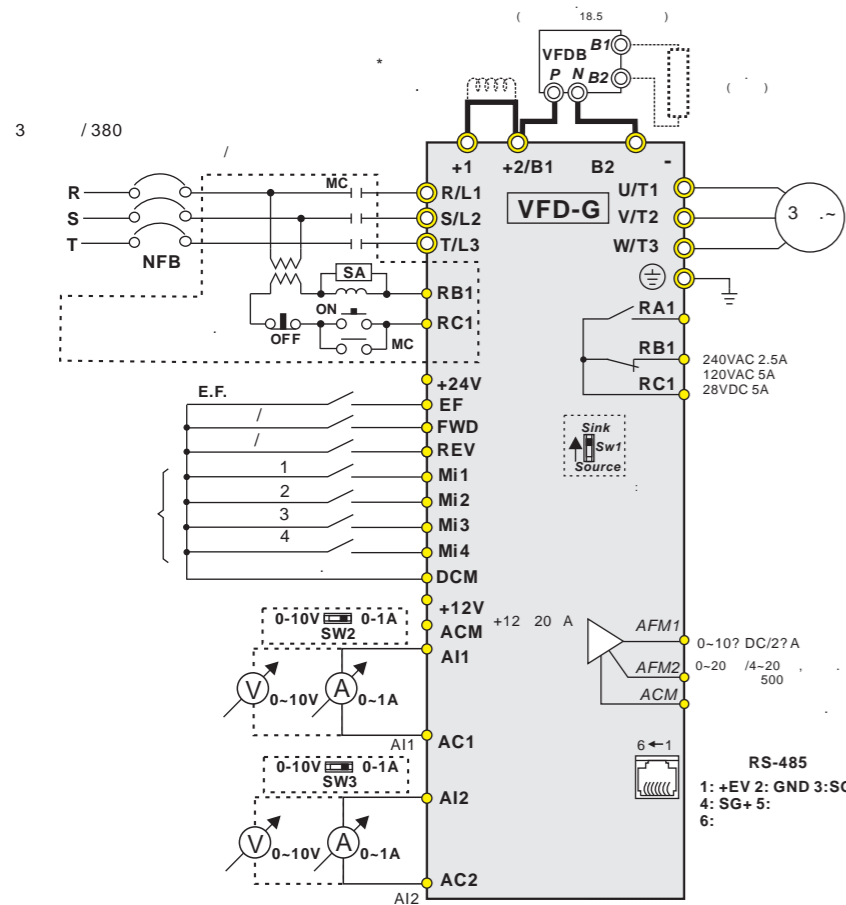

VFD 075 F 43 A -G
 (1) (2) (3) (4) (5)

1) DELTA
 2) (075=7.5)
 3) (43: 3 / 460)
 4)
 5) VFD-G

VFD-G

	50/60	3-		()
VFD055F43B-G		5,5	13,0	200,0 323,0 183,2
VFD075F43B-G		7,5	18,0	200,0 323,0 183,2
VFD110F43A-G		11,0	24,0	200,0 323,0 183,2
VFD150F43A-G		15,0	32,0	200,0 323,0 183,2
VFD185F43A-G		18,5	38,0	250,0 403,0 205,4
VFD220F43A-G		22,0	45,0	250,0 403,0 205,4
VFD300F43A-G		30,0	60,0	250,0 403,0 205,4
VFD370F43A-G		37,0	73,0	370,0 589,0 260,0
VFD450F43A-G	3-	45,0	91,0	370,0 589,0 260,0
VFD550F43A-G		55,0	110,0	370,0 589,0 260,0
VFD750F43A-G		75,0	150,0	370,0 595,0 260,0
VFD900F43C-G		90,0	180,0	370,0 595,0 260,0
VFD1100F43C-G		110,0	220,0	425,0 850,0 264,0
VFD1320F43A-G		132,0	260,0	425,0 850,0 264,0
VFD1600F43A-G		160,0	310,0	425,0 850,0 264,0
VFD1850F43A-G		185,0	370,0	547,0 1357,6 360,0
VFD2200F43A-G		220,0	460,0	547,0 1357,6 360,0

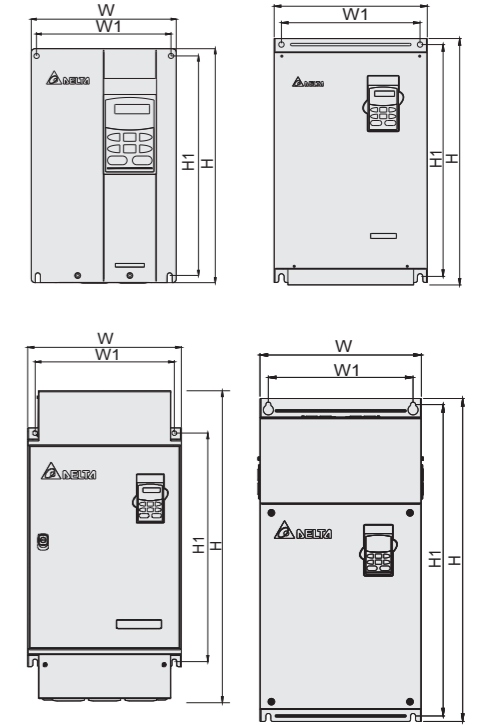

	SPWM ()	2-6 () ; V/f
()	0.1-120 (0.01)	
		: 150% 1
	150% 1 F>15 (5.5-90) ; 120% .1 .(110-220)	
/	1-36000/0.1-3600.0/0.01-360.00 (3)	
/ - (V/f)		20 150%
		▲ ▼
	2 , 15 , RS-485(MODBUS), UP/DOWN	
		RUN, STOP JOG
	FWD, REV, JOG () , RS-485 (MODBUS)	
	0 - 15, Jog, / , / .2/3/4, (NC, NO), (UP/DOWN)	
	AVR, S-	
	MODBUS,	
	1000	
	-10°C... +40°C	
/	-20°C ... +60°C	
	90% RH ()	
	9.80665 / ² (1G) 20 , 5.88 / ² (0.6G) 20 50	

VFD-VL

: 0~ 120 0.01
 : V/f, (Field-Oriented Control)
 S- : 150%
 (IM/SPM)
 RS-485 CAN
 ABZ Heidenhain
 PC
 : 136 11 ; 168 22

NEW



VFD 110 VL 23 A

- 23:230V
- 43:400V
- VFD-VL
- 055:7.5HP(5.5kW)
- 075:10HP(7.5kW)
- 110:15HP(11kW)
- 150:20HP(15kW)
- 185:25HP(18.5kW)
- 220:30HP(22kW)
- 300:20HP(30kW)
- 370:25HP(37kW)
- 450:30HP(45kW)
- 550:25HP(55kW)
- 750:30HP(75kW)

(Variable Frequency Drive)

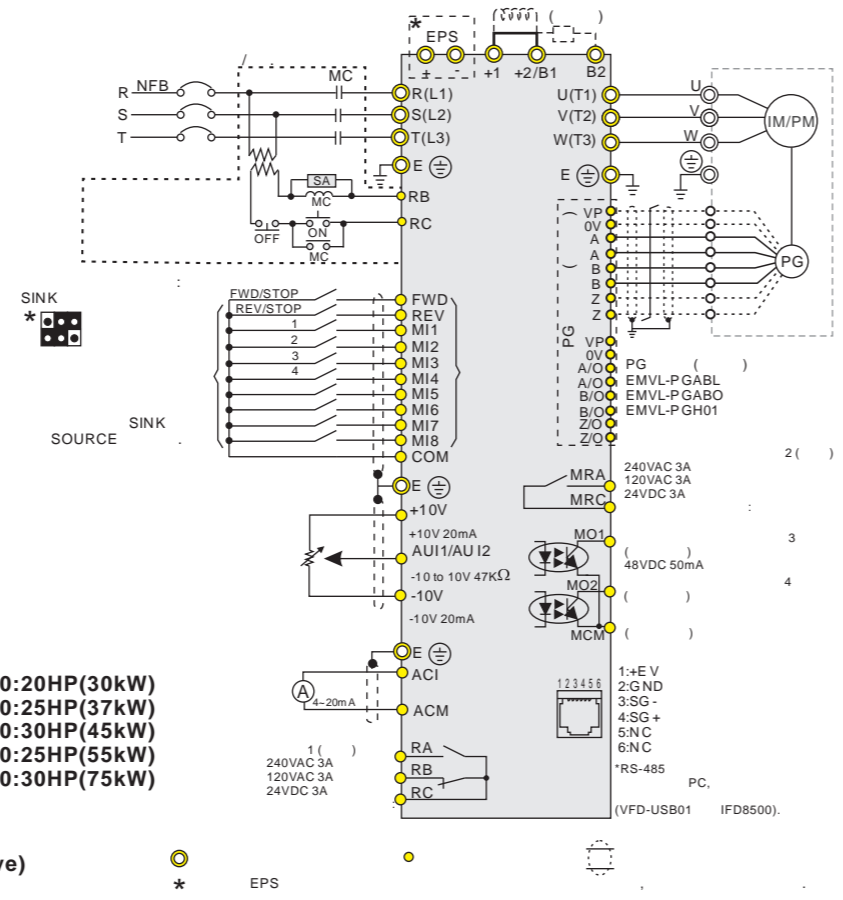

VFD-VL

	50/60	3-					
VFD055VL43A	3-	, 380 - 480	5,5	12,3	14	235,0	350,0 136,0 8
VFD075VL43A	3-	, 380 - 480	7,5	15,8	18	235,0	350,0 136,0 10
VFD110VL43A	3-	, 380 - 480	11,0	21	24	235,0	350,0 136,0 10
VFD150VL43A	3-	, 380 - 480	15,0	27	31	255,0	403,8 168,0 13
VFD185VL43A	3-	, 380 - 480	18,5	34	39	255,0	403,8 168,0 13
VFD220VL43A	3-	, 380 - 480	22,0	41	47	255,0	403,8 168,0 13
VFD300VL43A	3-	, 380 - 480	30,0	60	75	370,0	589,0 260,0 36
VFD370VL43A	3-	, 380 - 480	37,0	73	91	370,0	589,0 260,0 36
VFD450VL43A	3-	, 380 - 480	45,0	91	113	370,0	589,0 260,0 36
VFD550VL43A	3-	, 380 - 480	55,0	110	138	370,0	595,0 260,0 50
VFD750VL43A	3-	, 380 - 480	75,0	150	188	370,0	595,0 260,0 50

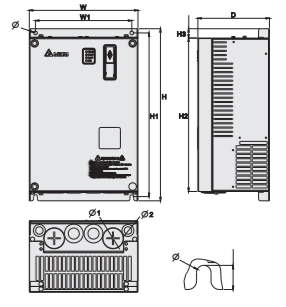

		1: V/F, 2: VF+PG, 3: SVC, 4: FOC+PG, 5: TQR+PG, 6: FOC+PG(PM)					
		150%	0.5	0	FOC + PG		
	1:100	(1:1000 PG)					
	± 0.5%	(± 0.02% PG)					
	5 (30)						
		0.00	120.00				
		+/- 0.005%,		+/- 0.5%			
	0.01	: 1/4096(12-bit)					
		200%					
		±5%					
/		0.00	600.00/	0.0	6000.0		
V/f		V/f		4-			
		0-10V, ±10V, 4~20mA					
		20%					
		220%	300%				
		50%					
		: 150%	60	:		200% 3	
		: Vdc > 400/800V;		: Vdc < 200/400V			
		(MOV)					
		NEMA 1/IP20					
		-10°C	45°C				
		-20°C	60°C				
		90% RH ()					
		9.80665m/s ² (1G)	20	, 5.88m/s ² (0.6G)		20 50	
		1000					

VFD-VE

c (FOC+PG):
 - 1 : 1000
 0 3600
 (SVC): - 1 : 100
 c (Torque+PG)
 (16)
 / -
 Y/D
 150% 0
 (PTC-)
 MODBUS (115200 /)

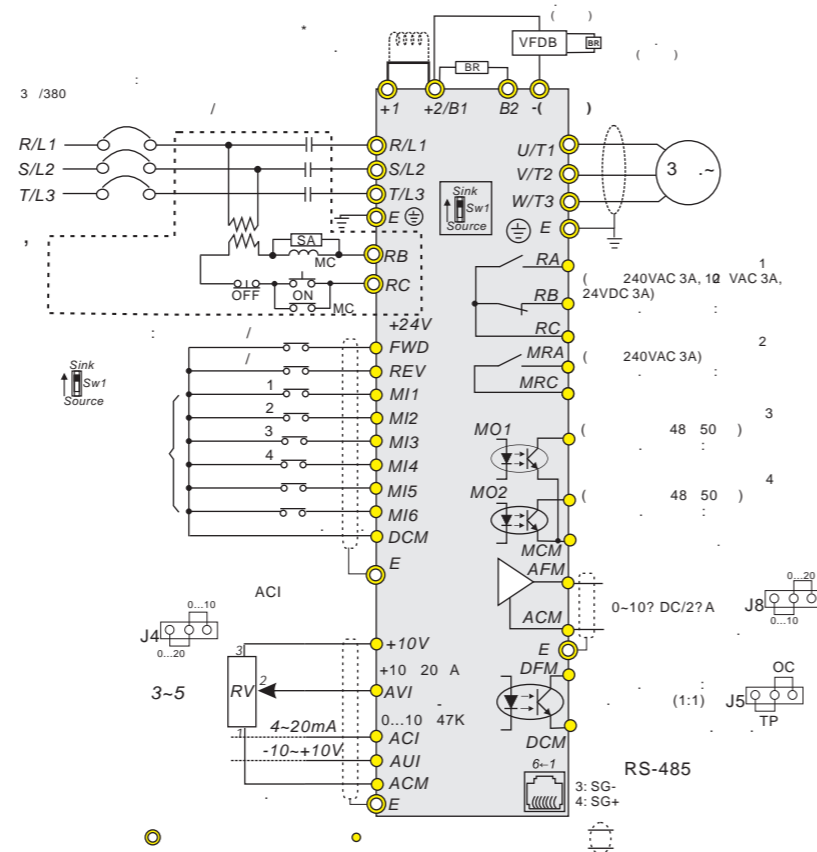

VFD-VE

	50/60	3-			()	
VFD007V43A-2	3-	, 380 - 480	0,75	3,0	3,8	150,0 260,0 160,2 2,7
VFD015V43A-2	3-	, 380 - 480	1,5	4,2	5,3	150,0 260,0 160,2 3,2
VFD022V43A-2	3-	, 380 - 480	2,2	6,0	7,5	150,0 260,0 160,2 4,5
VFD037V43A-2	3-	, 380 - 480	3,7	8,5	10,0	150,0 272,1 183,7 6,8
VFD055V43A-2	3-	, 380 - 480	5,5	13,0	16,0	200,0 323,0 183,2 8,0
VFD075V43A-2	3-	, 380 - 480	7,5	18,0	22,0	200,0 323,0 183,2 10,0
VFD110V43B-2	3-	, 380 - 480	11,0	24,0	30,0	200,0 323,0 183,2 10,0
VFD110V43A-2	3-	, 380 - 480	11,0	24,0	30,0	250,0 403,0 205,4 13,0
VFD150V43A-2	3-	, 380 - 480	15,0	32,0	40,0	250,0 403,0 205,4 13,0
VFD185V43A-2	3-	, 380 - 480	18,5	38,0	47,0	250,0 403,0 205,4 13,0
VFD220V43A-2	3-	, 380 - 480	22,0	45,0	56,0	250,0 403,0 205,4 13,0
VFD300V43A-2	3-	, 380 - 480	30,0	60,0	75,0	370,0 589,0 260,0 36,0
VFD370V43A-2	3-	, 380 - 480	37,0	73,0	91,0	370,0 589,0 260,0 36,0
VFD450V43A-2	3-	, 380 - 480	45,0	91,0	113,0	370,0 589,0 260,0 36,0
VFD550V43C-2	3-	, 380 - 480	55,0	110,0	138,0	370,0 595,0 260,0 50,0
VFD750V43C-2	3-	, 380 - 480	75,0	150,0	188,0	370,0 595,0 260,0 50,0

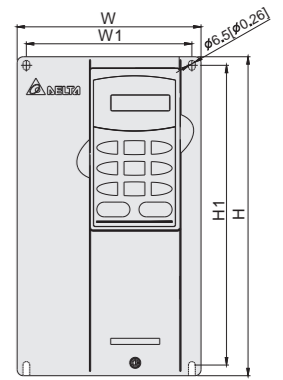

	SPWM () ; 1) V/f ; 2) V/f + PG ; 3) SVC () ; 4) FOC+PG () ; 5) TQR+PG ()
	: 150% 0.5 0 (FOC+PG)
	1:100 ((PG) 1:1000)
	0.5% ((PG) 0.02%)
	5 (FOC+PG 40)
()	0.00~600.00 (3600)
	±0.005% (), ±0.5% ()
	0.01 (), 12 ()
	: 200%
	±5%
/	0.00-600.00 / 0.00-600.00)
/ - (V/f)	4-
	(0...+10VDC; -10...+10VDC, 4... 20mA)
	20%
	300%
	50%
	150%
	1 ; 200% - 2
	: V > 400/800 VDC : V < 200/400 VDC
	(MOV)
	5
	IP20 ; NEMA1
	2
	1000
	-10°C... 40°C 11 ; -10°C ... 50°C 7.5
	-20°C ... 60°C
	90% RH ()
	9.80665 / ² (1G) 20 , 5.88 / ² (0.6G) 20 50



VFD-B

: 0.1~400 (2000)
 V/F
 (PG)
 MODBUS (38400 /),
 Profibus DP, DeviceNet, LonWorks
 (15)

1- / 220 : 0.75~2.2
 3- / 380 : 0.75~75
 3- / 600 : 0.75~75

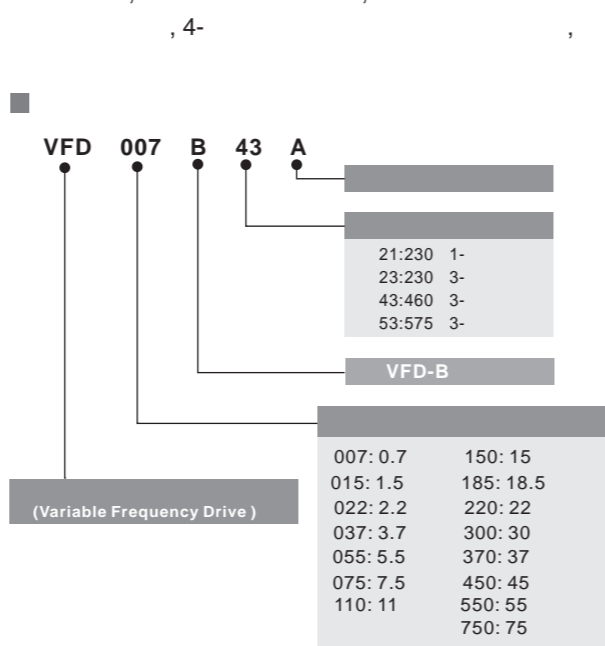
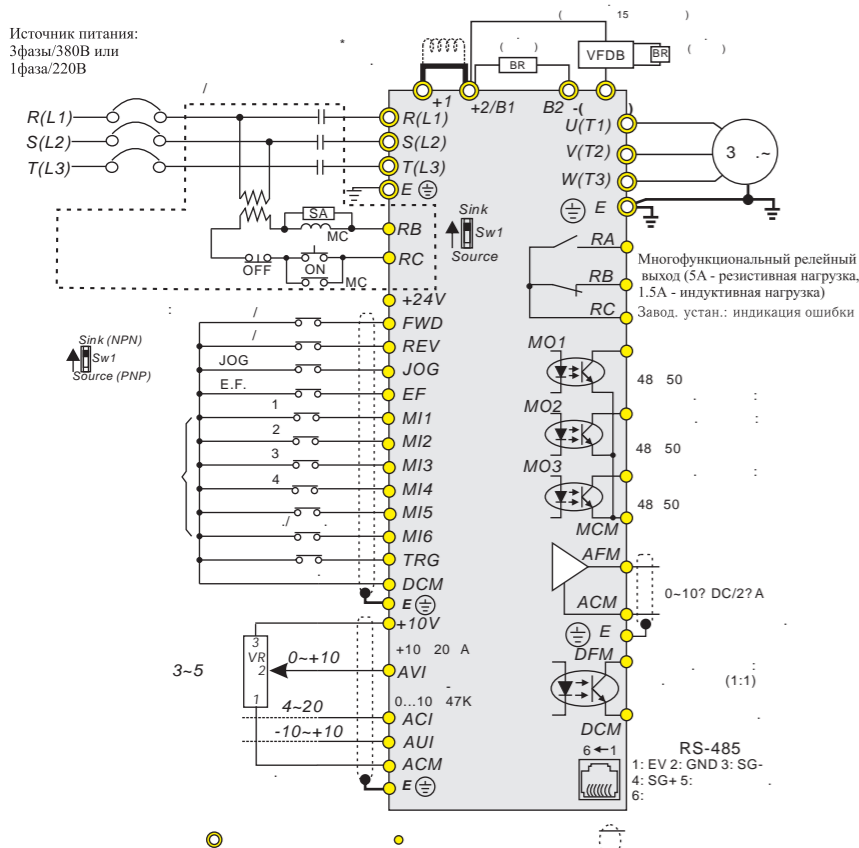

VFD-B

	50/60	3-		()	
VFD007B21A	1-	, 200 - 240		5,0	118,0 185,0 160,0 2,7
VFD007B43A	3-	, 380 - 480	0,75	2,7	118,0 185,0 145,0 2,7
VFD007B53A	3-	, 500 - 600		1,7	118,0 185,0 145,0 2,7
VFD015B21A	1-	, 200 - 240		7,0	118,0 185,0 160,0 3,2
VFD015B21B	1-	, 200 - 240	1,5	7,0	118,0 185,0 145,0 3,2
VFD015B43A	3-	, 380 - 480		4,2	118,0 185,0 160,0 3,2
VFD015B53A	3-	, 500 - 600		3,5	118,0 185,0 160,0 3,2
VFD022B21A	1-	, 200 - 240		11,0	150,0 260,0 160,2 4,5
VFD022B43B	3-	, 380 - 480	2,2	5,5	118,0 185,0 145,0 4,5
VFD022B53A	3-	, 500 - 600		4,5	118,0 185,0 145,0 4,5
VFD037B43A	3-	, 380 - 480		8,5	150,0 260,0 160,2 6,8
VFD037B53A	3-	, 500 - 600	3,7	7,5	150,0 260,0 160,2 6,8
VFD055B43A	3-	, 380 - 480		13,0	200,0 323,0 183,2 8,0
VFD055B53A	3-	, 500 - 600	5,5	10,0	200,0 323,0 183,2 8,0
VFD075B43A	3-	, 380 - 480		18,0	200,0 323,0 183,2 10,0
VFD075B53A	3-	, 500 - 600	7,5	13,5	200,0 323,0 183,2 10,0
VFD110B43A	3-	, 380 - 480		24,0	200,0 323,0 183,2 13,0
VFD110B53A	3-	, 500 - 600	11,0	19,0	200,0 323,0 183,2 13,0
VFD150B43A	3-	, 380 - 480		32,0	250,0 430,8 205,4 13,0
VFD150B53A	3-	, 500 - 600	15,0	22,0	250,0 430,8 205,4 13,0
VFD185B43A	3-	, 380 - 480		38,0	250,0 430,8 205,4 13,0
VFD185B53A	3-	, 500 - 600	18,5	27,0	250,0 430,8 205,4 13,0
VFD220B43A	3-	, 380 - 480		45,0	250,0 430,8 205,4 13,0
VFD220B53A	3-	, 500 - 600	22,0	34,0	250,0 430,8 205,4 13,0
VFD300B43A	3-	, 380 - 480		60,0	370,0 589,0 260,0 36,0
VFD300B53A	3-	, 500 - 600	30,0	41,0	370,0 589,0 260,0 36,0
VFD370B43A	3-	, 380 - 480		73,0	370,0 589,0 260,0 36,0
VFD370B53A	3-	, 500 - 600	37,0	52,0	370,0 589,0 260,0 36,0
VFD450B43A	3-	, 380 - 480		91,0	370,0 589,0 260,0 36,0
VFD450B53A	3-	, 500 - 600	45,0	62,0	370,0 589,0 260,0 36,0
VFD550B43A	3-	, 380 - 480		110,0	425,0 660,0 280,0 50,0
VFD550B43C	3-	, 380 - 480	55,0	110,0	370,0 589,0 260,0 36,0
VFD550B53A	3-	, 500 - 600		80,0	370,0 589,0 260,0 36,0
VFD750B43A	3-	, 380 - 480		150,0	425,0 660,0 280,0 50,0
VFD750B43	3-	, 380 - 480	75,0	150,0	370,0 595,0 260,0 36,0
VFD750B53A	3-	, 500 - 600		100,0	370,0 595,0 260,0 36,0

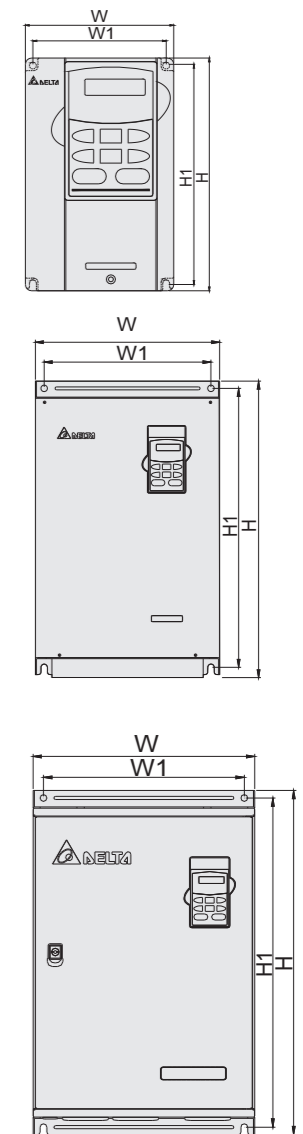

	SPWM () ; V/f
()	0.1~400 (0.01)
	: 150% 1
	150% 1
	0.1~400
/	0.1-3600 (4)
	AVR, S-
	MODBUS,
	, NPN/PNP
	IP20 ; NEMA1
	1000
	-10°C... 40°C (-10°C ... 50°C)
	-20°C ... 60°C
	90% RH ()
	9.80665 / ² (1G) 20 , 5.88 / ² (0.6G) 20 50

